

Cub Cadet.

OPERATOR'S MANUAL

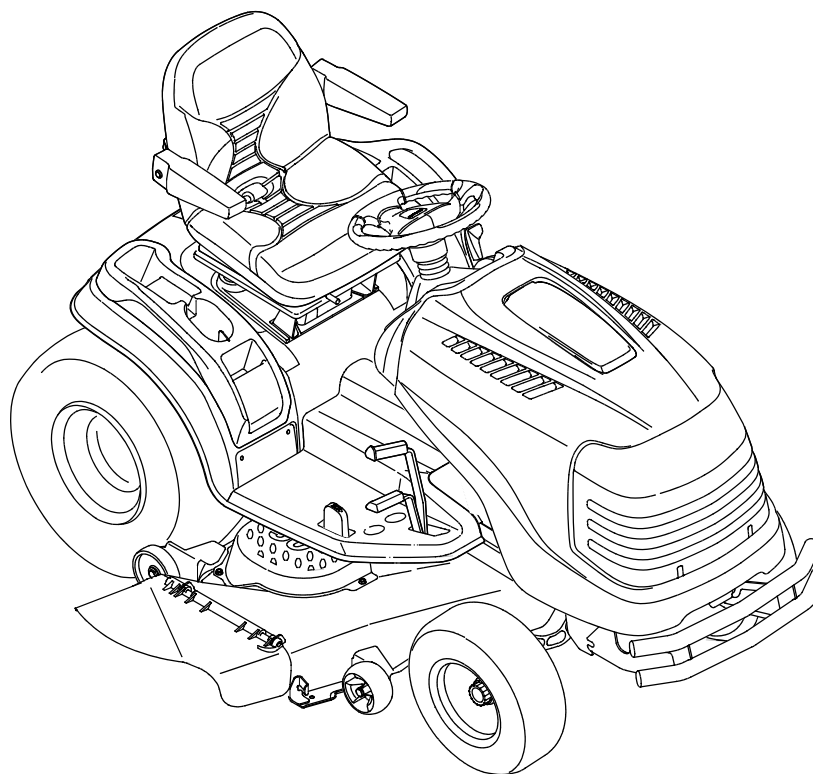

Series 2500 Garden Tractor - Model GT 2550

⚠ WARNING

**READ AND FOLLOW ALL SAFETY RULES AND INSTRUCTIONS IN THIS MANUAL
BEFORE ATTEMPTING TO OPERATE THIS MACHINE.
FAILURE TO COMPLY WITH THESE INSTRUCTIONS MAY RESULT IN PERSONAL INJURY.**

CUB CADET LLC, P.O. BOX 361131 CLEVELAND, OHIO 44136-0019

Thank You

Thank you for purchasing a Garden Tractor manufactured by Cub Cadet LLC. It was carefully engineered to provide excellent performance when properly operated and maintained.

Please read this entire manual prior to operating the equipment. It instructs you how to safely and easily set up, operate and maintain your machine. Please be sure that you, and any other persons who will operate the machine, carefully follow the recommended safety practices at all times. Failure to do so could result in personal injury or property damage.

All information in this manual is relative to the most recent product information available at the time of printing. Review this manual frequently to familiarize yourself with the machine, its features and operation. Please be aware that this Operator's Manual may cover a range of product specifications for various models. Characteristics and features discussed and/or illustrated in this manual may

not be applicable to all models. Cub Cadet LLC reserves the right to change product specifications, designs and equipment without notice and without incurring obligation.

This product has met the rigid safety standards of the Outdoor Power Equipment Institute and an independent testing laboratory. If you have any problems or questions concerning the machine, phone your local Cub Cadet dealer or contact us directly. Cub Cadet's Customer Support telephone numbers, website address and mailing address can be found on this page. We want to ensure your complete satisfaction at all times.

Throughout this manual, all references to right and left side of the machine are observed from the operating position.

Table of Contents

Section 1: Safe Operation Practices	3	Section 7: Troubleshooting	41
Section 2: Assembly & Set-Up	8	Section 8: Replacement Parts	43
Section 3: Controls and Features	12	Section 9: Attachments & Accessories	44
Section 4: Operation.....	16	Section 10: Specifications	45
Section 5: Maintenance & Adjustment.....	22	Warranties	47
Section 6: Service	32		

Record Product Information

Before setting up and operating your new equipment, please locate the model plate on the equipment and record the information in the provided area to the right. The chassis model plate, showing the factory model number and serial number can be found at the front of the right hand frame channel just behind the right front wheel. This information will be necessary, should you seek technical support via our web site or with your local Cub Cadet dealer.

MODEL NUMBER

--	--	--	--	--	--	--	--	--	--	--

SERIAL NUMBER

--	--	--	--	--	--	--	--	--	--	--

Customer Support

If you have difficulty assembling this product or have any questions regarding the controls, operation, or maintenance of this machine, you can seek help from the experts. Choose from the options below:

- ◇ Visit us on the web at www.cubcadet.com
- ◇ Locate your nearest Cub Cadet Dealer at (877) 282-8684
- ◇ Write us at Cub Cadet LLC • P.O. Box 361131 • Cleveland, OH • 44136-0019

Section 1: Important Safe Operation Practices



WARNING: This symbol points out important safety instructions which, if not followed, could endanger the personal safety and/or property of yourself and others. Read and follow all instructions in this manual before attempting to operate this machine. Failure to comply with these instructions may result in personal injury.

When you see this symbol. **HEED ITS WARNING!**

CALIFORNIA PROPOSITION 65



WARNING: Engine Exhaust, some of its constituents, and certain vehicle components contain or emit chemicals known to State of California to cause cancer and birth defects or other reproductive harm.



WARNING: Battery posts, terminals, and related accessories contain lead and lead compounds, chemicals known to the State of California to cause cancer and reproductive harm. *Wash hands after handling*



DANGER: This machine was built to be operated according to the rules for safe operation practices in this manual. As with any type of power equipment, carelessness or error on the part of the operator can result in serious injury. This machine is capable of amputating hands and feet and throwing objects. Failure to observe the following safety instructions could result in serious injury or death.

Children

1. Tragic accidents can occur if the operator is not alert to the presence of children. Children are often attracted to the machine and the mowing activity. They do not understand the dangers. Never assume that children will remain where you last saw them.
 - a. Keep children out of the mowing area and in watchful care of a responsible adult other than the operator.
 - b. Be alert and turn machine off if a child enters the area.
 - c. Before and while backing, look behind and down for small children.
 - d. Never carry children, even with the blade(s) shut off. They may fall off and be seriously injured or interfere with safe machine operation.
 - e. Use extreme care when approaching blind corners, doorways, shrubs, trees or other objects that may block your vision of a child who may run into the machine.
 - f. **To avoid back-over accidents, always disengage the cutting blade(s) before shifting into Reverse. If equipped, the "Reverse Caution Mode" should not be used when children or others are around.**
 - g. Keep children away from hot or running engines. They can suffer burns from a hot muffler.
 - h. Remove key when machine is unattended to prevent unauthorized operation.
2. Never allow children under 14 years of age to operate this machine. Children 14 and over should read and understand the instructions and safe operation practices in this manual and on the machine and should be trained and supervised by an adult.

Operation

Safe Handling of Gasoline:

1. To avoid personal injury or property damage use extreme care in handling gasoline. **Gasoline is extremely flammable and the vapors are explosive.** Serious personal injury can occur when gasoline is spilled on yourself or your clothes which can ignite. Wash your skin and change clothes immediately.
 - a. Use only an approved gasoline container.
 - b. Never fill containers inside a vehicle or on a truck or trailer bed with a plastic liner. Always place containers on the ground away from your vehicle before filling.

- c. When practical, remove gas-powered equipment from the truck or trailer and refuel it on the ground. If this is not possible, then refuel such equipment on a trailer with a portable container, rather than from a gasoline dispenser nozzle.
 - d. Keep the nozzle in contact with the rim of the fuel tank or container opening at all times until fueling is complete. Do not use a nozzle lock-open device.
 - e. Extinguish all cigarettes, cigars, pipes and other sources of ignition.
 - f. Never fuel machine indoors.
 - g. Never remove gas cap or add fuel while the engine is hot or running. Allow engine to cool at least two minutes before refueling.
 - h. Never over fill fuel tank. Fill tank to no more than ½ inch below bottom of filler neck to allow space for fuel expansion.
 - i. Replace gasoline cap and tighten securely.
 - j. If gasoline is spilled, wipe it off the engine and equipment. Move machine to another area. Wait 5 minutes before starting the engine.
 - k. To reduce fire hazards, keep machine free of grass, leaves, or other debris build-up. Clean up oil or fuel spillage and remove any fuel soaked debris.
 - l. Never store the machine or fuel container inside where there is an open flame, spark or pilot light as on a water heater, space heater, furnace, clothes dryer or other gas appliances.
 - m. Allow a machine to cool at least five minutes before storing.
- 7. Plan your mowing pattern to avoid discharge of material toward roads, sidewalks, bystanders and the like. Also, avoid discharging material against a wall or obstruction which may cause discharged material to ricochet back toward the operator.
 - 8. Always wear safety glasses or safety goggles during operation and while performing an adjustment or repair to protect your eyes. Thrown objects which ricochet can cause serious injury to the eyes.
 - 9. Wear sturdy, rough-soled work shoes and close-fitting slacks and shirts. Loose fitting clothes and jewelry can be caught in movable parts. Never operate this machine in bare feet or sandals.
 - 10. Be aware of the mower and attachment discharge direction and do not point it at anyone. Do not operate the mower without the discharge cover or entire grass catcher in its proper place.
 - 11. Do not put hands or feet near rotating parts or under the cutting deck. Contact with the blade(s) can amputate hands and feet.
 - 12. A missing or damaged discharge cover can cause blade contact or thrown object injuries.
 - 13. Stop the blade(s) when crossing gravel drives, walks, or roads and while not cutting grass.
 - 14. Watch for traffic when operating near or crossing roadways. This machine is not intended for use on any public roadway.
 - 15. Do not operate the machine while under the influence of alcohol or drugs.
 - 16. Mow only in daylight or good artificial light.
 - 17. Never carry passengers.
 - 18. Disengage blade(s) before shifting into reverse. Back up slowly. Always look down and behind before and while backing to avoid a back-over accident.
 - 19. Slow down before turning. Operate the machine smoothly. Avoid erratic operation and excessive speed.
 - 20. Disengage blade(s), set parking brake, stop engine and wait until the blade(s) come to a complete stop before removing grass catcher, emptying grass, unclogging chute, removing any grass or debris, or making any adjustments.
 - 21. Never leave a running machine unattended. Always turn off blade(s), place transmission in neutral, set parking brake, stop engine and remove key before dismounting.
 - 22. Use extra care when loading or unloading the machine into a trailer or truck. This machine should not be driven up or down ramp(s), because the machine could tip over, causing serious personal injury. The machine must be pushed manually on ramp(s) to load or unload properly.
 - 23. Muffler and engine become hot and can cause a burn. Do not touch.
 - 24. Check overhead clearances carefully before driving under low hanging tree branches, wires, door openings etc., where the operator may be struck or pulled from the machine, which could result in serious injury.

General Operation:

- 1. Read, understand, and follow all instructions on the machine and in the manual(s) before attempting to assemble and operate. Keep this manual in a safe place for future and regular reference and for ordering replacement parts.
- 2. Be familiar with all controls and their proper operation. Know how to stop the machine and disengage them quickly.
- 3. Never allow children under 14 years old to operate this machine. Children 14 years old and over should read and understand the operation instructions and safety rules in this manual and should be trained and supervised by a parent.
- 4. Never allow adults to operate this machine without proper instruction.
- 5. To help avoid blade contact or a thrown object injury, keep bystanders, helpers, children and pets at least 75 feet from the machine while it is in operation. Stop machine if anyone enters the area.
- 6. Thoroughly inspect the area where the equipment is to be used. Remove all stones, sticks, wire, bones, toys, and other foreign objects which could be picked up and thrown by the blade(s). Thrown objects can cause serious personal injury.

25. Disengage all attachment clutches, depress the brake pedal completely and shift into neutral before attempting to start engine.
26. Your machine is designed to cut normal residential grass of a height no more than 10". Do not attempt to mow through unusually tall, dry grass (e.g., pasture) or piles of dry leaves. Dry grass or leaves may contact the engine exhaust and/or build up on the mower deck presenting a potential fire hazard.
27. Use only accessories and attachments approved for this machine by the machine manufacturer. Read, understand and follow all instructions provided with the approved accessory or attachment.
28. Data indicates that operators, age 60 years and above, are involved in a large percentage of riding mower-related injuries. These operators should evaluate their ability to operate the riding mower safely enough to protect themselves and others from serious injury.
29. If situations occur which are not covered in this manual, use care and good judgment. Contact your customer service representative for assistance.

Slope Operation:

Slopes are a major factor related to loss of control and tip-over accidents which can result in severe injury or death. All slopes require extra caution. If you cannot back up the slope or if you feel uneasy on it, do not mow it.

For your safety, use the slope gauge included as part of this manual to measure slopes before operating this machine on a sloped or hilly area. If the slope is greater than 15 degrees as shown on the slope gauge, do not operate this machine on that area or serious injury could result.

Do:

1. Mow up and down slopes, not across. Exercise extreme caution when changing direction on slopes.
2. Watch for holes, ruts, bumps, rocks, or other hidden objects. Uneven terrain could overturn the machine. Tall grass can hide obstacles.
3. Use slow speed. Choose a low enough speed setting so that you will not have to stop or shift while on the slope. Tires may lose traction on slopes even though the brakes are functioning properly. Always keep machine in gear when going down slopes to take advantage of engine braking action.
4. Follow the manufacturer's recommendations for wheel weights or counterweights to improve stability.
5. Use extra care with grass catchers or other attachments. These can change the stability of the machine.
6. Keep all movement on the slopes slow and gradual. Do not make sudden changes in speed or direction. Rapid engagement or braking could cause the front of the machine to lift and rapidly flip over backwards which could cause serious injury.
7. Avoid starting or stopping on a slope. If tires lose traction, disengage the blade(s) and proceed slowly straight down the slope.

Do Not:

1. Do not turn on slopes unless necessary; then, turn slowly and gradually downhill, if possible.
2. Do not mow near drop-offs, ditches or embankments. The mower could suddenly turn over if a wheel is over the edge of a cliff, ditch, or if an edge caves in.
3. Do not try to stabilize the machine by putting your foot on the ground.
4. Do not use a grass catcher on steep slopes.
5. Do not mow on wet grass. Reduced traction could cause sliding.
6. Do not shift to neutral and coast downhill. Over-speeding may cause the operator to lose control of the machine resulting in serious injury or death.
7. Do not tow heavy pull behind attachments (e.g. loaded dump cart, lawn roller, etc.) on slopes greater than 5 degrees. When going down hill, the extra weight tends to push the tractor and may cause you to lose control. (e.g. tractor may speed up, braking and steering ability are reduced, attachment may jack-knife and cause tractor to overturn).

Towing:

1. Tow only with a machine that has a hitch designed for towing. Do not attach towed equipment except at the hitch point.
2. Follow the manufacturer's recommendation for weight limits for towed equipment and towing on slopes.
3. Never allow children or others in or on towed equipment.
4. On slopes, the weight of the towed equipment may cause loss of traction and loss of control.
5. Travel slowly and allow extra distance to stop.
6. Do not shift to neutral and coast downhill.

Service

1. Never run an engine indoors or in a poorly ventilated area. Engine exhaust contains carbon monoxide, an odorless, and deadly gas.
2. Before cleaning, repairing, or inspecting, make certain the blade(s) and all moving parts have stopped. Disconnect the spark plug wire and ground against the engine to prevent unintended starting.
3. Periodically check to make sure the blades come to complete stop within approximately (5) five seconds after operating the blade disengagement control. If the blades do not stop within this time frame, your machine should be serviced professionally by an authorized MTD Service Dealer.
4. Check brake operation frequently as it is subjected to wear during normal operation. Adjust and service as required.

5. Check the blade(s) and engine mounting bolts at frequent intervals for proper tightness. Also, visually inspect blade(s) for damage (e.g., excessive wear, bent, cracked). Replace the blade(s) with the original equipment manufacturer's (O.E.M.) blade(s) only, listed in this manual. "Use of parts which do not meet the original equipment specifications may lead to improper performance and compromise safety!"
6. Mower blades are sharp. Wrap the blade or wear gloves, and use extra caution when servicing them.
7. Keep all nuts, bolts, and screws tight to be sure the equipment is in safe working condition.
8. Never tamper with the safety interlock system or other safety devices. Check their proper operation regularly.
9. After striking a foreign object, stop the engine, disconnect the spark plug wire(s) and ground against the engine. Thoroughly inspect the machine for any damage. Repair the damage before starting and operating.
10. Never attempt to make adjustments or repairs to the machine while the engine is running.
11. Grass catcher components and the discharge cover are subject to wear and damage which could expose moving parts or allow objects to be thrown. For safety protection, frequently check components and replace immediately with original equipment manufacturer's (O.E.M.) parts only, listed in this manual. "Use of parts which do not meet the original equipment specifications may lead to improper performance and compromise safety!"
12. Do not change the engine governor settings or over-speed the engine. The governor controls the maximum safe operating speed of the engine.
13. Maintain or replace safety and instruction labels, as necessary.
14. Observe proper disposal laws and regulations for gas, oil, etc. to protect the environment.

Do not modify engine

To avoid serious injury or death, do not modify engine in any way. Tampering with the governor setting can lead to a runaway engine and cause it to operate at unsafe speeds. Never tamper with factory setting of engine governor.

Notice Regarding Emissions

Engines which are certified to comply with California and federal EPA emission regulations for SORE (Small Off Road Equipment) are certified to operate on regular unleaded gasoline, and may include the following emission control systems: Engine Modification (EM) and Three Way Catalyst (TWC) if so equipped.

Spark Arrestor



WARNING: This machine is equipped with an internal combustion engine and should not be used on or near any unimproved forest-covered, brushcovered or grass-covered land unless the engine's exhaust system is equipped with a spark arrester meeting applicable local or state laws (if

any).

If a spark arrester is used, it should be maintained in effective working order by the operator. In the State of California the above is required by law (Section 4442 of the California Public Resources Code). Other states may have similar laws. Federal laws apply on federal lands.

A spark arrester for the muffler is available through your nearest engine authorized service dealer or contact the service department, P.O. Box 361131 Cleveland, Ohio 44136-0019.

Average Useful Life

According to the Consumer Products Safety Commission (CPSC) and the U.S. Environmental Protection Agency (EPA), this product has an *Average Useful Life* of seven (7) years, or 270 hours of operation. At the end of the *Average Useful Life*, buy a new machine or have the machine inspected annually by an authorized service dealer to ensure that all mechanical and safety systems are working properly and not worn excessively. Failure to do so can result in accidents, injuries or death.



WARNING: Your Responsibility—Restrict the use of this power machine to persons who read, understand and follow the warnings and instructions in this manual and on the machine.

SAVE THESE INSTRUCTIONS!

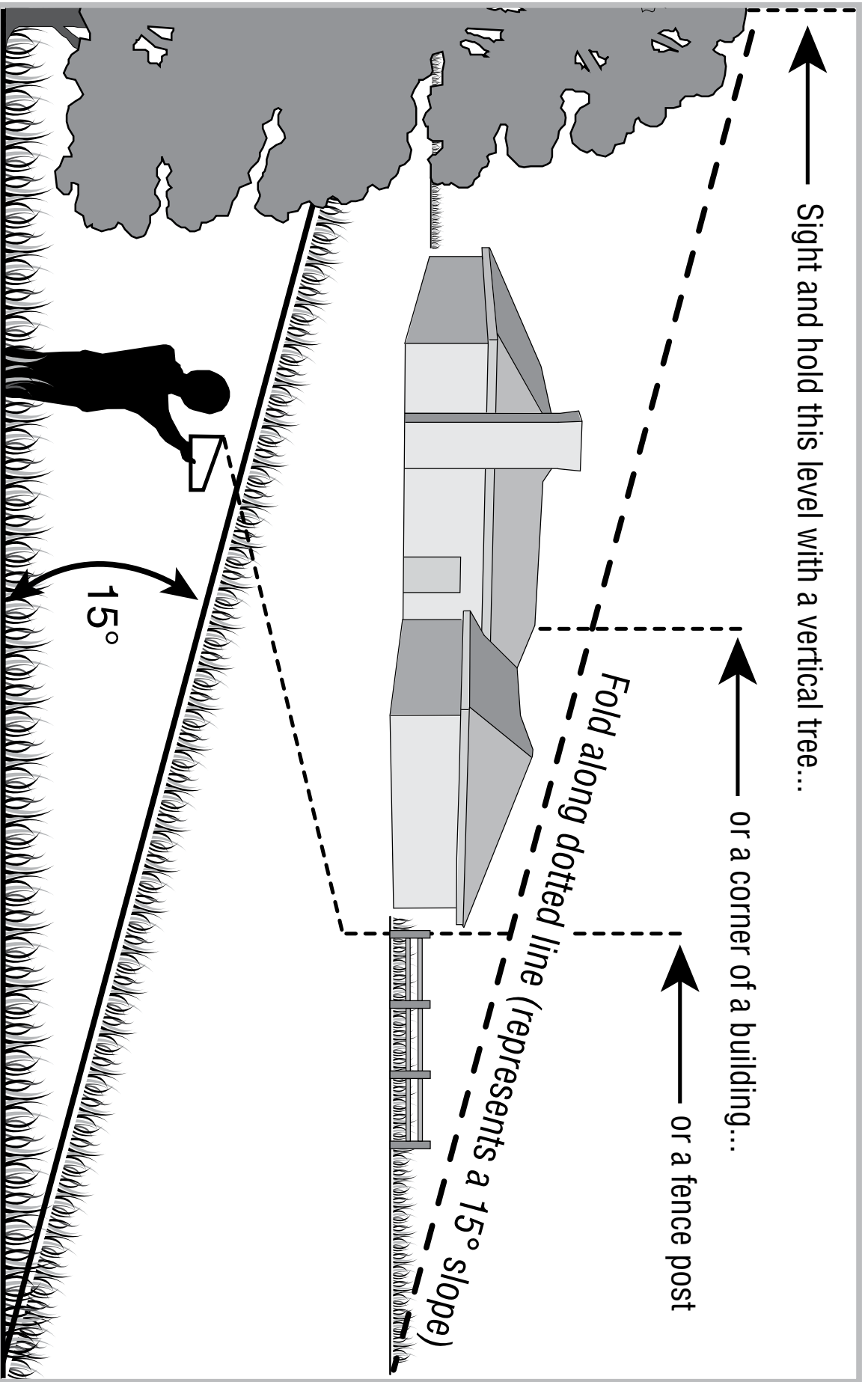

Use this page as a guide to determine slopes where you may not operate safely.

WARNING: Do not operate your lawn mower on such slopes. Do not mow on inclines with a slope in excess of 15 degrees (a rise of approximately 2-1/2 feet every 10 feet). A riding mower could overturn and cause serious injury. Operate riding mowers up and down slopes, never across the face of slopes.

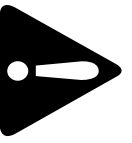

Section 2: Assembly & Set-Up

TRACTOR STEERING WHEEL

For shipping purposes, the steering wheel was removed from the steering shaft. Pivot the seat rearward and remove any packaging material from the seat. Cut the ties securing the steering wheel and remove any packaging material. Install the steering wheel as follows:

1. Locate the steering bellow and note the riser at one end of the bellow. With the riser facing upward, slide the bellow onto the steering shaft. See Figure 2-1.

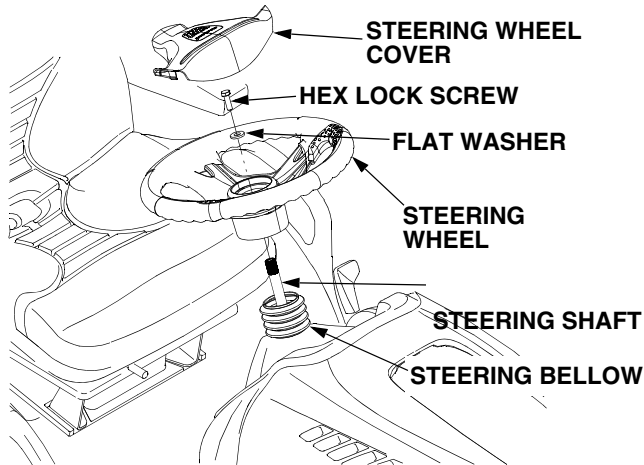

Figure 2-1

2. Pry the steering wheel cover off the steering wheel and remove the hex lock screw and flat washer.
3. Check that the tractor front tires are in the straight position. If not, temporarily slide the steering wheel onto the steering shaft and straighten the front wheels. Carefully remove the steering wheel.
4. From the operator's seat, rotate the steering wheel so that the spokes of the wheel are in the basic 'T' position. Align the splines of the steering wheel hub with the splines of the steering shaft and press the steering wheel onto the shaft. See Figure 2-1.
5. Position the steering bellow so that its riser is inside the bottom of the steering wheel.
6. Slide the flat washer onto the hex lock screw. Insert the screw through the center hole of the steering wheel and thread into the steering shaft. Fully tighten the lock screw into the steering shaft.
7. Position the steering wheel cover to align with the steering wheel. Press the cover downward until it snaps into place on the steering wheel.

CONNECT THE BATTERY



WARNING: Battery posts, terminals and related accessories contain lead and lead compounds. Wash hands after handling.

The tractor is shipped with an activated sealed battery. The positive battery cable is factory connected. The negative cable must be connected.

Note: Make sure the ignition switch is in the "OFF" position before attaching the battery cables.

1. Pull the protective cap, if present, off the negative terminal of the battery, and remove the hex cap screw and nut from the free end of the negative battery cable.
2. Connect the negative battery cable (black) and green ground wire to the negative terminal (NEG) of the battery using the hex cap screw and nut.
3. If equipped, slide the black terminal cover over the negative terminal of the battery.

DECK INSTALLATION

The mower deck is normally installed on the tractor at the factory, but in some instances the deck may be shipped secured to the side panel of the tractor's shipping crate. If the mower deck is not installed on the tractor, cut the tie strap(s) securing the deck to the side panel of the crate, and use a hoist, or the help of an assistant, to carefully lift the mower deck out of the shipping crate. Install the deck on the tractor as follows:

1. Cut the tie strap securing the PTO belt and remove the belt from the deck. Remove the deck wash system nozzle adapter from manual bag and store for future use.



WARNING: Before performing the deck installation, place the PTO switch in the "OFF" position, engage the parking brake, turn the ignition key to the "OFF" position and remove the key from the switch. When handling the mower deck, be careful not to cut yourself on the sharp blades.

2. Position the tractor and mower deck on a firm, level surface.
3. Position the deck on the right side of the tractor with the front of the deck facing toward the front of the tractor (Refer to Figure 2-2).

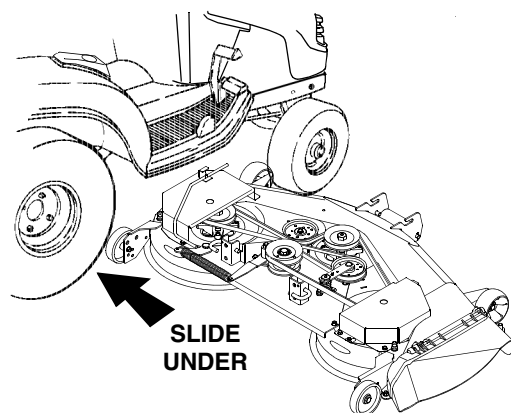

Figure 2-2



WARNING: To avoid possible equipment damage, make sure that the tractor implement lift handle is raised to its highest setting before sliding the deck under the tractor.

NOTE: Turning the steering wheel as you maneuver the deck under the tractor can help in positioning the deck beneath the tractor.

4. Raise the tractor implement lift handle to its highest setting and slide the deck under the tractor. Make sure the slot in each rear deck bracket aligns with the implement lift link on each side of the tractor (See Figure 2-3).

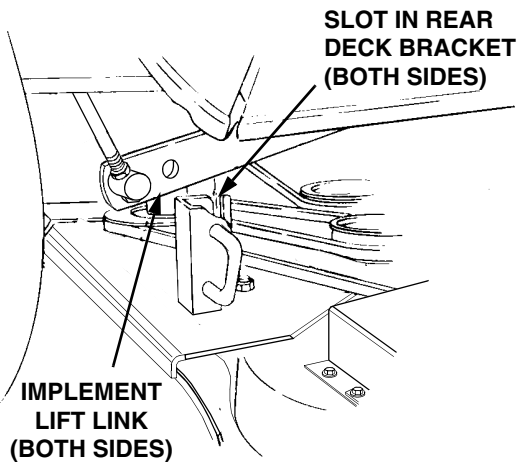

Figure 2-3

NOTE: If installing the deck on a new tractor, the front lift rod/bracket assembly is already installed on the front of the tractor. Cut the cable tie used to hold the front lift rod up to the tractor frame during shipment, then proceed to step 5.

5. Refer to Figure 2-4 to ensure the correct orientation of the front lift rod/bracket assembly [the form (bend) in sides of rod point downward]. From the front of the tractor, push downward and hold the tractor quick-attach rod. Slide the shoulder bolts on each side of the front lift rod/

bracket assembly fully into the left and right tractor latch receivers. Release the tractor quick-attach rod to capture the front lift rod/bracket assembly in the tractor latch receivers

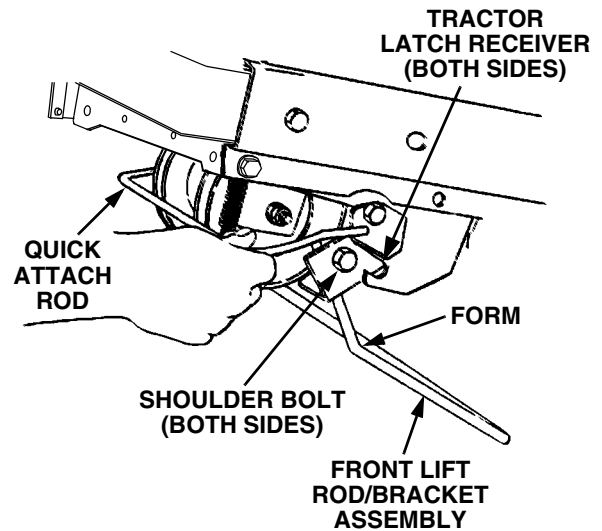

Figure 2-4

6. While holding the front lift rod up, slide the mower deck forward until the rod aligns with both front roller bracket slots. Lower the lift rod into the front roller bracket slots and slide the deck rearward to engage the lift rod fully forward in the slots of the deck front roller bracket (See Figure 2-5).

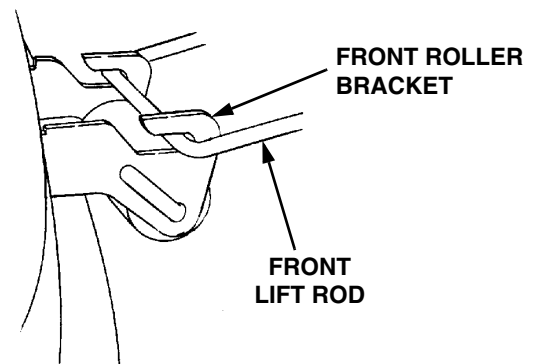

Figure 2-5

- If not already done, pull the deck support pins outward, turn downward and release so both spring-loaded pins are held in the disengaged position against the outer surface of the deck brackets (See Figure 2-6).

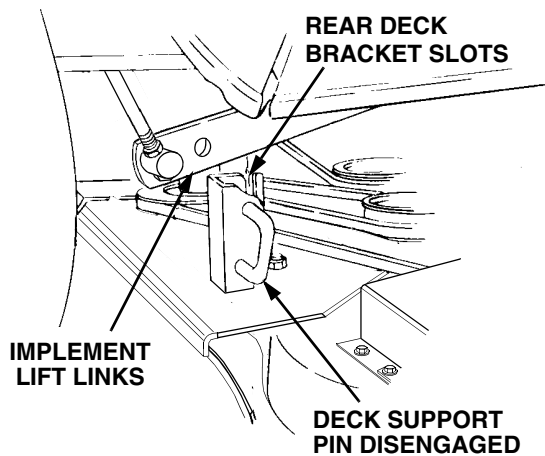

Figure 2-6

- Carefully guide the tractor implement lift links (left and right) into the rear deck bracket slots (left and right) as the tractor implement lift handle is lowered to its lowest setting (Refer to Figure 2-7).
- Pull both deck support pins outward and rotate rearward to disengage the outer surface of the rear deck brackets. Release the pins, making certain each deck support pin passes through the inner hole of the rear deck bracket. The spring tension will push the pins inward and, if aligned, through the hole in each implement lift link (Refer to Figure 2-7).

NOTE: It may be necessary to lift each side of the deck and maneuver it slightly to align the support pins with the holes of the lift links. Make certain the support pins are fully extended through the lift links to prevent the mower deck from disengaging the lift links while mowing.

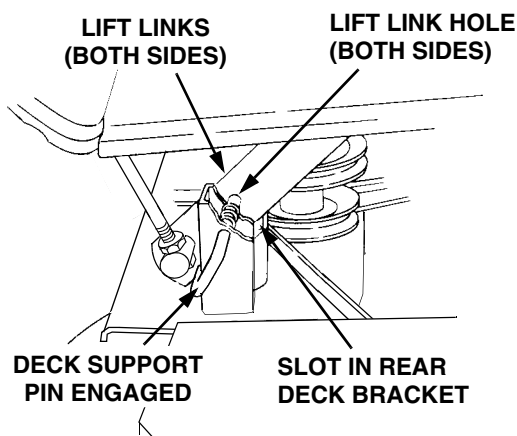

Figure 2-7



WARNING: The deck idler arm lever is spring loaded. Release it slowly.

- Disengage the deck idler arm lever from its stop bracket and release the spring tension by rotating the lever out and rearward (See Figure 2-8).

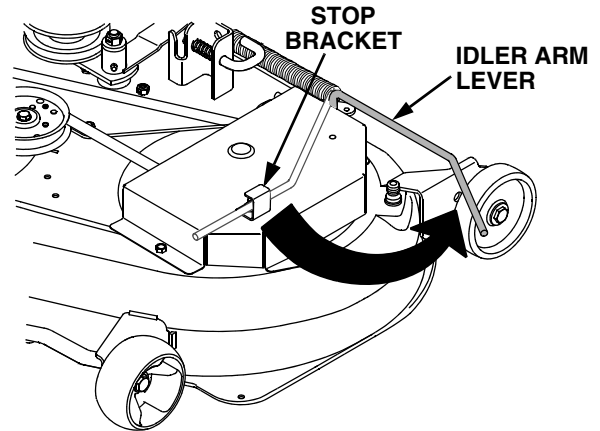

Figure 2-8



WARNING: The exhaust system is HOT. To avoid personal injury, allow the engine and exhaust system to cool before proceeding with the following PTO belt installation instructions.

- Open the tractor hood. From the front of the tractor, pass the belt upward in front of the lower front pulleys and inside the tractor frame (Refer to Figure 2-10).
- Loop the PTO belt with the narrow side of the 'V' belt inward; then maneuver the loop of the belt up between the front of the PTO pulley and the heat shield on the front of the engine. Place the belt into the groove of the PTO pulley. See Figure 2-9.

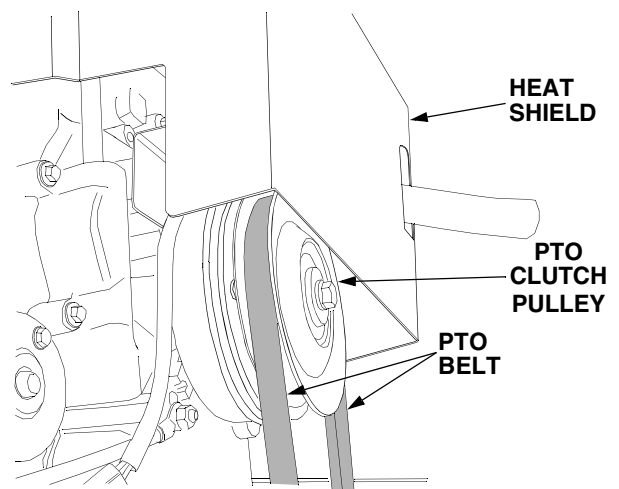

Figure 2-9

13. Twist the two sides of the PTO belt 1/4 turn inward to engage the narrow sides of the belt into the grooves of the two tractor front-lower pulleys (See Figure 2-10).
14. Route the PTO belt through the center of the front lift rod, toward the center of the deck. Ensure that the forward end of the belt remains positioned inside the front lower pulleys.

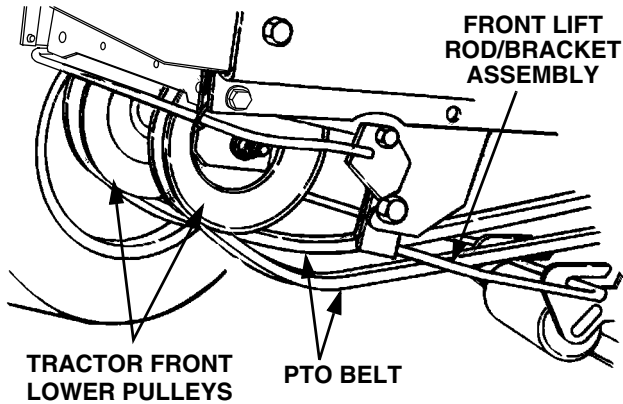

Figure 2-10

15. Working from the left/rear of the mower deck, install the rearward end of the PTO belt on the upper pulley of the deck center double-pulley (Refer to Figure 2-11). Ensure that the narrow side of the belt engages the groove of the upper pulley, and that there is no more than a 1/4 twist in the belt between the front pulleys and the double pulley.

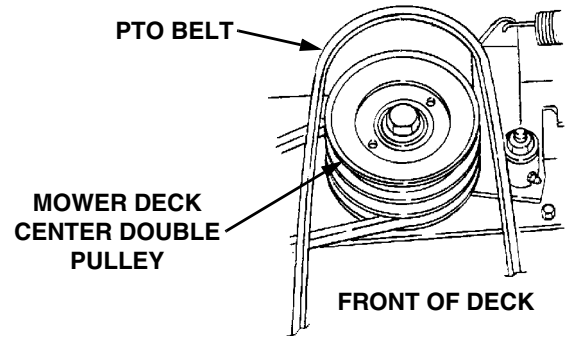

Figure 2-11

16. While holding the belt in position, rotate the deck idler arm lever into its stop bracket to tension the PTO belt (Refer to Figure 2-12). Make certain the PTO belt is properly positioned in the PTO clutch pulley and both lower front pulleys. Reposition if necessary.

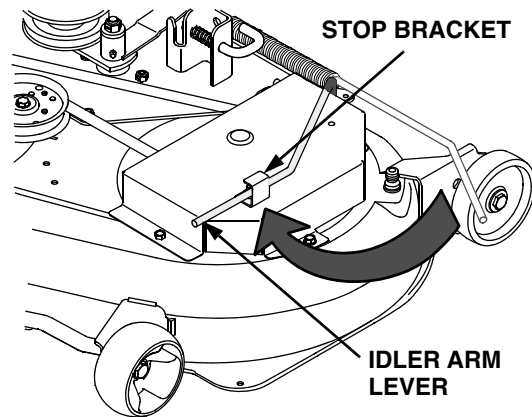
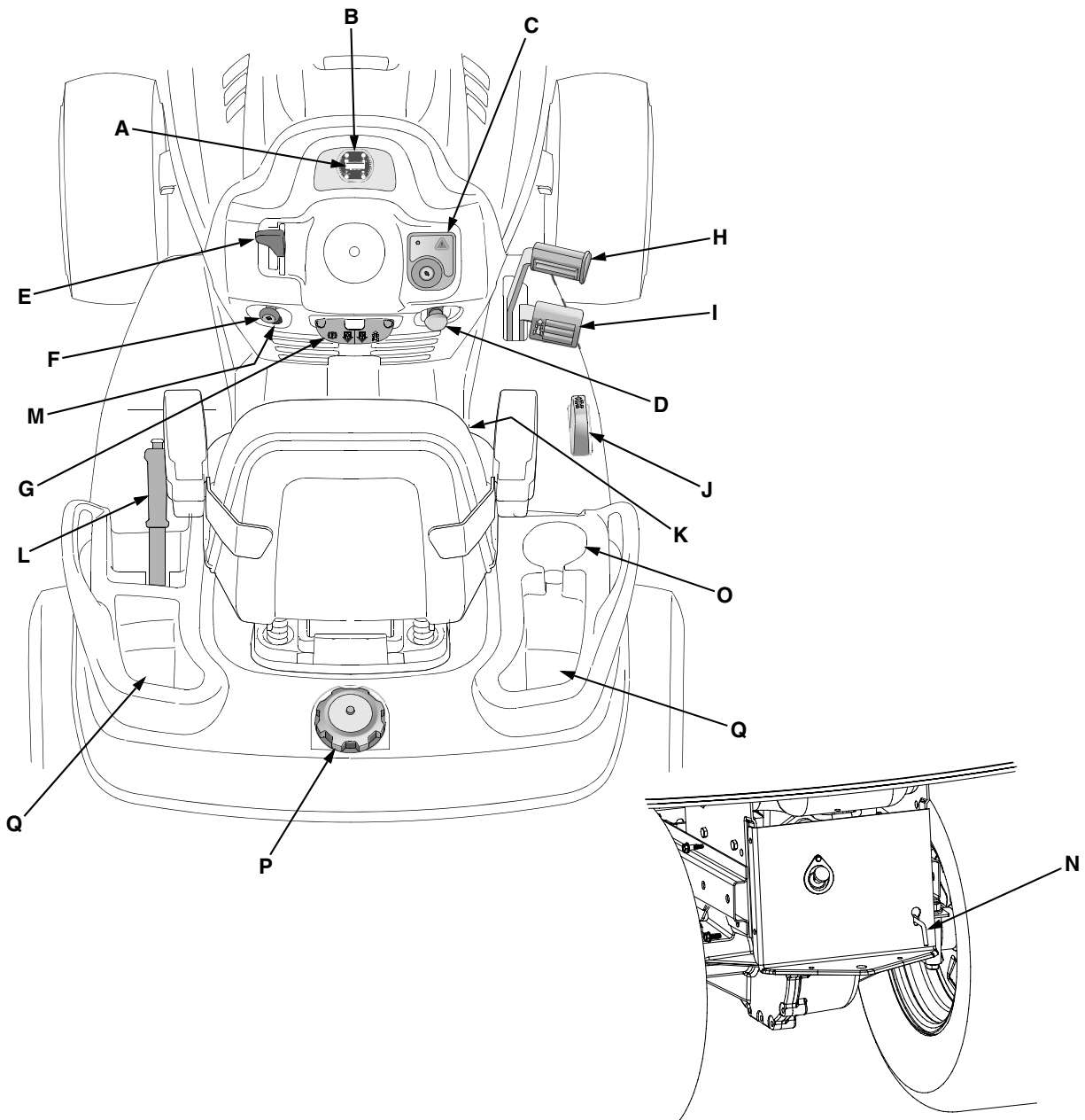

Figure 2-12

17. Raise the deck by moving the implement lift handle to its highest setting.

Section 3: Controls & Features



- | | |
|---|--------------------------------------|
| A. Hour Meter/Battery Display | J. Reverse Control Pedal |
| B. Indicator Panel/Hour Meter | K. Seat Adjustment Lever |
| C. Key Switch Module | L. Lift Handle |
| D. Power Take-Off (PTO) Control Switch | M. 12V Power Outlet |
| E. Throttle Control Lever | N. Transmission Release Lever |
| F. Choke Control | O. Cup Holder |
| G. Parking Brake/Cruise Lever | P. Fuel Fill Cap |
| H. Brake Pedal | Q. Storage Tray |
| I. Forward Control Pedal | |

Figure 3-1

A. HOUR METER/BATTERY DISPLAY

The hour meter records and digitally displays the hours that the tractor has been operated (tenths of an hour - right most digit).

NOTE: The hour meter is activated whenever the ignition switch is turned to an 'On' position. Keep a record of the actual hours of operation to assure all maintenance procedures are completed according to the instructions in this manual.

- When key is turned to the "ON" position, the battery indicator light briefly illuminates and the battery voltage is briefly displayed. The display then changes to the accumulated hours.
- The hour meter display will also remind the operator of maintenance intervals for changing the engine oil. The LCD display will alternately flash, "CHG" ; "OIL"; and the accumulated hours for five minutes after every 50 hours of recorded operation. The maintenance interval lasts for two hours (from 50-52, 100-102, 150-152, etc.). The LCD will flash as described for five minutes every time the tractor's engine is started during this maintenance interval. **Follow the oil change intervals provided in this manual.**

B. INDICATOR PANEL/HOUR METER

The indicator panel/hour meter uses indicator lights to display the status of various functions of the tractor, and also records the accumulated hours of operation.

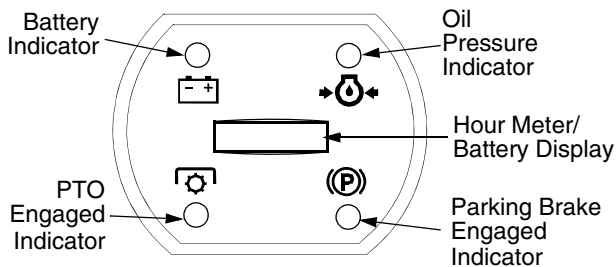

Figure 3-2

Indicator Panel Features

Battery Indicator (Refer to Figure 3-2)

- Illuminates when the ignition switch is turned to an ON position and the engine is not started.
- Illuminates to indicate the battery voltage has dropped below 11.5 (+0.5/-1.0) DC volts (battery voltage is also displayed on the hour meter). If this indicator/display comes on during operation, check the battery and charging system for possible causes and/or contact your *Cub Cadet* dealer.

Oil Pressure Indicator (Refer to Figure 3-2)

- This warning lamp indicates low engine oil pressure. If this indicator illuminates, stop the tractor immediately and check the engine oil level. If the oil level is within the operating range, but the light remains on, contact your *Cub Cadet* dealer.

NOTE: The oil pressure indicator may illuminate when the key switch is turned to an on position, but should turn off when the engine is started.

PTO Engaged Indicator (Refer to Figure 3-2)

- This indicator illuminates when the key switch is turned to the "Start" position while the PTO switch is in the "Engaged" position. Check this indicator if the engine will not crank with the key switch in the "Start" position. If necessary, move the PTO switch to the "Disengaged" position.

Brake Engaged Indicator (Refer to Figure 3-2)

- This indicator illuminates when the key switch is turned to the "Start" position and the brake pedal is not fully depressed. Check this indicator if the engine will not crank with the key switch in the "Start" position. Fully depress the brake pedal.

C. KEY SWITCH MODULE

The key switch module consists of a four position key switch, the "Reverse Push Button", and a red indicator light. See Figure 3-3.

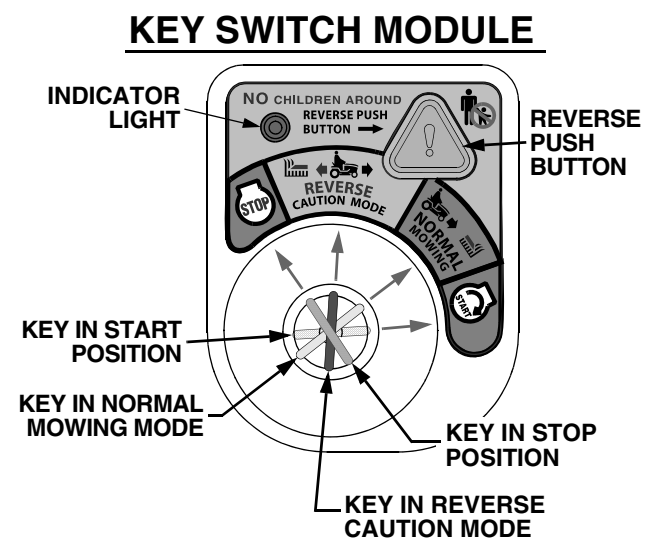

Figure 3-3

The four key positions of key switch module (Refer to Figure 3-3) and their functions are as follows:

- **STOP** — Stops the tractor engine and shuts down the tractor's electrical circuits.
- **REVERSE CAUTION MODE** — This position allows the machine to be operated in reverse with the blades (PTO) engaged.
- **NORMAL MOWING** — The normal operating position. All safety interlock circuits are activated and the blades (PTO) will disengage when the tractor is driven in the reverse direction.
- **START** — Energizes the starter motor to crank and start the tractor engine. Release the key as soon as the engine starts and the key will return to "NORMAL MOWING" position.



WARNING: To prevent accidental starting and/or battery discharge, remove the key from the key switch when the tractor is not in use.

REVERSE PUSH BUTTON — The orange/triangular button at the top/right corner of the key switch module activates the system that allows the tractor's blades (PTO) to remain engaged when the tractor is driven in the reverse direction. The key must be turned to the "REVERSE CAUTION MODE" and the operator must be in the tractor seat prior to depressing the button to activate the system.

The **RED INDICATOR LIGHT** at the top/left corner of the key switch module comes "ON" to alert the operator that the key has been turned to the "Reverse Caution Mode" position, the "Reverse Push Button" has been depressed, and that the blades will remain engaged when the machine is driven in reverse.

IMPORTANT: *Mowing in reverse is not recommended.*

D. POWER TAKE-OFF (PTO) CONTROL SWITCH

The power take-off (PTO) switch operates the front electric PTO clutch. Pull the switch knob upward to engage, or push downward to disengage the PTO clutch.

E. THROTTLE CONTROL LEVER

This lever controls the speed of the engine. When set in a given position, the control cable will maintain a uniform engine speed.

NOTE: *When using PTO operated equipment, the throttle lever must be in the "FAST" position.*



This symbol shows slow position.



This symbol shows fast position.

F. CHOKE CONTROL

The choke control is operated manually. Pull the knob out to choke the engine; push the knob in to open the choke.

G. PARKING BRAKE /CRUISE CONTROL LEVER

The parking brake/cruise control lever is located in the center of the dash panel below the steering wheel. This is a single lever that is used to engage both the parking brake and the cruise control feature.

To engage the parking brake, fully depress the brake pedal and push downward on the parking brake/cruise control lever. Hold the lever down while releasing the brake pedal. The lever should lock in the down position and the parking brake should be engaged.

NOTE: *Always engage the parking brake when dismounting the tractor.*

To engage the cruise control, depress the forward control pedal to attain your desired speed; then push the parking brake/cruise control lever downward. While holding the lever down, release pressure from the drive pedal. This will engage the cruise control and allow the tractor to remain at approximately that same speed while removing your foot from the forward drive pedal. Refer to "Operation" for more instructions regarding the cruise control

H. BRAKE PEDAL

The brake pedal is located at the front of the right running board above the forward control pedal. Press down to stop the tractor and disengage the cruise control. The brake pedal must be fully depressed to activate the safety interlock switch when starting the tractor.

I. FORWARD CONTROL PEDAL

The forward control pedal is located at the front of the right running board below the brake pedal. Slowly press down on the pedal to start moving forward. The forward ground speed of the tractor is directly affected by the distance the pedal is depressed.

J. REVERSE CONTROL PEDAL



WARNING: Always look down and behind before and while backing. Do not operate the tractor when children or others are around. Stop the tractor immediately if someone enters the area.

The reverse control pedal is located in the right front running board rearward of the brake and forward control pedals. Press the pedal downward to move in reverse.

K. SEAT ADJUSTMENT LEVER

The seat adjustment lever (See Figure 3-4) is used to move the seat forward or rearward to a comfortable operating position. See seat adjustment instructions in "Maintenance & Adjustments".

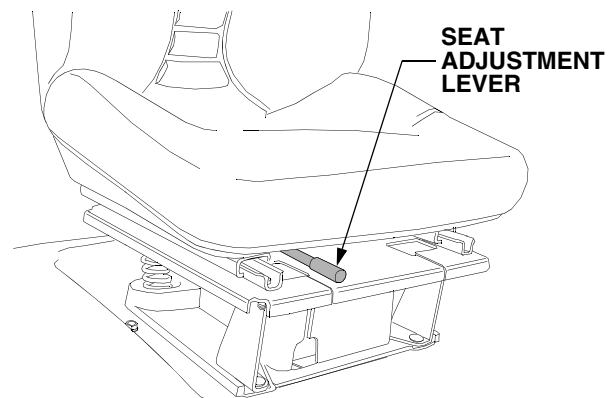

Figure 3-4

L. LIFT HANDLE

The lift handle is located in the left fender and is used to raise and lower equipment used with the tractor. The equipment can be set in any of six positions by depressing the top button on the handle, moving the handle to the desired position, then releasing the button. It may be necessary to push or pull slightly on the handle to depress the button. A lift assist spring reduces the effort needed to lift attachments. To adjust assist spring tension refer to "Maintenance & Adjustments".

M. 12V POWER OUTLET

The 12V power outlet is located below the choke control on the left side of the dash panel. It is used for the convenience of plugging in accessories that require a power source with a maximum load of 5 amps at 12 volts.

N. TRANSMISSION RELEASE LEVER

The transmission release lever is located at the back of the tractor in the rear drawbar. When engaged, this lever opens a hydrostatic pump bypass valve, which allows the tractor to be pushed short distances by hand.

To engage the release lever, lift and pull the lever rearward through the keyhole until the flange on the rod is outside the drawbar. Lower the lever into the slot and release. To disengage the release lever, pull back on the lever, lift out of the slot and release.

O. CUP HOLDER

The cup holder is located on the right fender.

P. FUEL FILL CAP

The fuel tank is located under the rear fender. The filler cap is in the center/rear of the fender.

Q. STORAGE TRAY

The storage trays are located near the rear of the seat on each fender. Use the trays to carry small loose articles while operating the tractor.

FUSES

The two fuses are located under the hood behind the dash panel. Fuses are installed to protect the tractor's electrical circuitry and components from damage caused by excessive amperage.

SAFETY INTERLOCK SWITCHES

This tractor is equipped with a safety interlock system for the protection of the operator. If the interlock system should ever malfunction, do not operate the tractor. Contact your authorized *Cub Cadet* Dealer. The safety interlock system prevents the engine from cranking or starting unless the brake pedal is fully depressed, and the PTO switch is in the "OFF" position.

The safety interlock system will automatically shut off the engine if the operator leaves the seat before engaging the brake lock.

The safety interlock system will automatically shut off the engine if the operator leaves the seat with the PTO in the "RUN" position, regardless of whether the brake lock is engaged. The PTO switch must be moved to the "OFF" position to restart the engine.

With key switch in "NORMAL MOWING" position:

The safety interlock system will automatically shut off the PTO if the *reverse control pedal* is depressed with the PTO in the "RUN" position. To re-engage the PTO, release the reverse control pedal, move the PTO switch to the "OFF" position, then again pull the switch to the "RUN" position.

OPENING THE TRACTOR HOOD



WARNING: If the engine has been recently run, the engine, muffler and surrounding metal surfaces will be hot and can cause burns to the skin. Allow the tractor to cool and use caution when opening the hood.

The hood of the tractor raises from the front of the tractor and pivots upward toward the dash panel. The hood is equipped with gas cylinders to aid in lifting the hood and to hold the hood in the up position.

To raise the hood proceed as follows:

- Locate the latch bracket at the bottom/center of the front of the hood. See Figure 3-5.

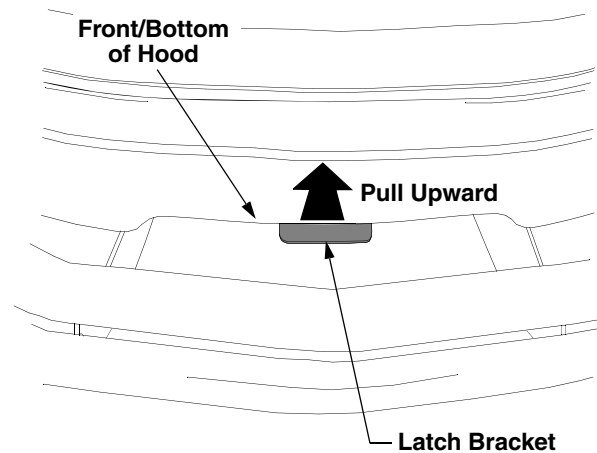

Figure 3-5

- Pull the latch bracket upward until it releases from the latch rod; then lift the hood.

To close the hood, push the hood firmly downward until the latch bracket engages the latch rod.

NOTE: To ensure the hood is locked in the down position, push the latch bracket fully downward after closing the hood.

NOTE: Some front mounted attachments must be fully lowered to allow the hood to be opened. Use care to avoid damage to the hood.

Section 4: Operation



WARNING: Before you operate the tractor, study this manual carefully. Familiarize yourself with the operations of all the instruments and controls. Learn to operate this machine safely. Don't risk INJURY or DEATH.

1. Before starting the engine, the operator must be seated, the PTO switch must be in the "OFF" position and the brake pedal must be fully depressed.
2. Keep all shields in place. Keep away from moving parts.
3. NO RIDERS! Keep all people a safe distance away. Look down and behind to both sides before and while backing up.
4. DO NOT direct the mower discharge at people.
5. Avoid slopes. Tractors can roll over.
6. Before leaving the operator's seat: Shut off the PTO, engage the parking brake, shut off the engine and remove the ignition key. Wait for all movement to stop before servicing or cleaning.
7. Do not fill the fuel tank when the engine is running or while the engine is hot. Tighten the fuel cap securely.

BEFORE STARTING YOUR TRACTOR

1. Read and understand this entire manual.



WARNING: Gasoline is extremely flammable and its vapors can explode if ignited. Store gasoline only in approved containers, in well ventilated, unoccupied buildings, away from sparks or flames. Do not fill the fuel tank while the engine is hot or running, since spilled fuel could ignite if it comes in contact with hot parts or sparks from ignition. Do not start the engine near spilled fuel. Never use gasoline as a cleaning agent.

2. This engine is certified to operate on unleaded gasoline. For best results, fill the fuel tank with only clean, fresh, unleaded gasoline with a pump sticker octane rating of 87 or higher. In countries using the Research method, it should be 90 octane minimum.

Unleaded gasoline is recommended because it leaves less combustion chamber deposits and reduces harmful exhaust emissions. Leaded gasoline is not recommended and must not be used where exhaust emissions are regulated.

NOTE: Purchase gasoline in small quantities. Do not use gasoline left over from the previous season, to minimize gum deposits in the fuel system.

Gasohol (up to 10% ethyl alcohol, 90% unleaded gasoline by volume) is an approved fuel. Other gasoline/alcohol blends are not approved.

Methyl Tertiary Butyl Ether (MTBE) and unleaded gasoline blends (up to a maximum of 15% MTBE by volume) are approved fuels. Other gasoline/ether blends are not approved.

3. Check the engine and transmission oil levels.
4. Clean the air cleaner element if necessary.
5. Check the tire inflation pressures.
6. Adjust the seat for operator's maximum comfort, visibility, and for maintaining complete control of the tractor.

SAFETY INTERLOCK SYSTEM



WARNING: This unit is equipped with a safety interlock system designed for the protection of the operator. Do not operate the tractor if any part of the interlock system is malfunctioning. Periodically check the functions of the interlock system for proper operation as described below:

- The safety interlock system prevents the engine from cranking or starting unless the brake pedal is fully depressed and the PTO clutch engagement switch is in the "OFF" position.
- The safety interlock system will automatically shut off the engine if the operator leaves the seat before engaging the brake pedal lock.
- The safety interlock system will automatically shut off the engine if the operator leaves the seat with the PTO engaged, regardless of whether the brake pedal lock is engaged.
- **With key switch in "NORMAL MOWING" position:** The safety interlock system will automatically disengage the PTO if the reverse control pedal is pressed down with the PTO in the "RUN" position. To re-engage the PTO, release the reverse control pedal, push the PTO switch down to the "OFF" position, and then pull the PTO switch upward to engage the PTO.

STARTING THE ENGINE



WARNING: For personal safety, the operator must be sitting in the tractor seat when starting the engine. Never try to start the engine while standing on the ground.

1. Operator must be sitting in the tractor seat.
2. Pull choke control knob to full choke position. Less choking may be necessary due to variations in temperature, grade of fuel, etc. Little or no choking will be needed when the engine is warm.
3. Place the throttle midway between the "SLOW" and "FAST" position.
4. Place the PTO switch in the "OFF" position.
5. Fully depress the brake pedal.
6. Turn the ignition key clockwise to the "START" position and release it as soon as the engine starts. However, do not crank the engine continuously for more than 10 seconds at a time. If the engine does not start, allow a 60 second cool down period between starting attempts. Failure to follow these guidelines can burn out, or permanently damage, the starter motor.

NOTE: If the engine develops sufficient speed to disengage the starter but does not keep running, allow the engine to come to a complete stop before attempting to restart the engine. If the starter is engaged while the flywheel is rotating, the starter pinion and the flywheel ring gear may clash resulting in damage to the starter.

IMPORTANT: If the starter does not turn the engine over, shut off starter immediately. Do not make further attempts. Contact your Cub Cadet dealer.

7. After the engine starts, slowly release the brake pedal. As the engine warms up, gradually push the choke control knob all the way in. Do not use the choke to enrich the fuel mixture, except as necessary to start the engine.

NOTE: Upon start-up, a metallic ticking may occur. This is caused by hydraulic lifter leakdown. Run the engine for 5 minutes. The noise will normally cease in the first minute. If noise continues, run the engine at mid-throttle for 20 minutes. If the noise persists, contact your Cub Cadet dealer.

COLD WEATHER STARTING HINTS



WARNING: Engine exhaust gases are dangerous. Do not run the engine in a confined area such as a storage building any longer than is necessary. Immediately move the tractor outdoors.

1. When starting the engine at temperatures near or below freezing, ensure the correct viscosity motor oil is used in the engine and the battery is fully charged.

2. Disengage all possible external loads.
3. Be sure the battery is in good condition. A warm battery has much more starting capacity than a cold battery.
4. Use fresh winter grade fuel. Winter grade gasoline has higher volatility to improve starting. Do not use gasoline left over from summer.
5. Follow the previous instruction for STARTING THE ENGINE.

JUMP STARTING



WARNING: Failure to use this jump starting procedure could cause sparking, which could result in an explosion of either battery.

1. Attach the first jumper cable from the positive terminal of the good battery to the positive terminal of the dead battery.
2. Attach the second jumper cable from the negative terminal of the good battery to the FRAME OF THE UNIT WITH THE DEAD BATTERY.

IMPORTANT: If the jumper battery is installed on a vehicle (e.g. car, truck), do NOT start the vehicle's engine when jump starting your tractor.

STOPPING THE ENGINE



WARNING: Remove the key from the ignition switch to prevent accidental starting or battery discharge if the equipment is left unattended.

Place the PTO switch in the "OFF" position. Move the throttle control lever between the "MID" and "FAST" positions. Wait a moment to allow the engine speed to stabilize, then turn the ignition key to the "STOP" position. Remove the key from the ignition switch.

TRACTOR BREAK-IN PROCEDURE

IMPORTANT: Never operate a new engine immediately under full load. Break it in carefully as shown in the table below.

Period	Engine Throttle Control Lever Position			Load
	1/2	3/4	Full	
1st hour		X		None
2nd hour	X		X	Light drawbar load or Mowing with tractor at slow groundspeed
3rd through 12th hour		X	X	Medium drawbar load or Normal mowing

DRIVING THE TRACTOR

NOTE: Avoid sudden starts, excessive speed and sudden stops.



WARNING: Do not leave the seat of the tractor without disengaging the PTO and engaging the parking brake. If leaving the tractor unattended, turn the ignition key off and remove the key.

IMPORTANT: When using PTO driven equipment, the throttle lever should be in the “FAST” position.

- Depress the brake pedal to release the parking brake and let the pedal up. Move the throttle lever to the position where the engine operates best for the load to be handled (usually full throttle).

Driving With Forward Or Reverse Pedals.



WARNING: Do not use the forward or reverse control pedals to change the direction of travel when the tractor is in motion. Use the brake pedal to bring the tractor to a stop before changing direction with either the forward or reverse control pedal.

1. To move in the forward direction, slowly depress the forward control pedal until the desired speed is achieved.
2. To move in the reverse direction, check that the area behind is clear then fully depress the reverse control pedal. Always look down and behind before and while backing up.

Using The Cruise Control Feature.

IMPORTANT: The cruise control feature can only be operated in the forward direction.

1. Slowly depress the forward control pedal until the desired speed is achieved.
2. Lightly push the parking brake/cruise control lever downward as far as possible and hold in this position.
3. While continuing to hold the parking brake/cruise control lever down, lift your foot from the forward control pedal (you should feel the cruise latch engage).
4. If properly engaged, the cruise lever and forward control pedal should lock in the down position, and the tractor will maintain the approximate same forward speed.

5. Disengage the cruise control using one of the following methods:

- Depress the brake pedal to disengage the cruise control and stop the tractor.
- Lightly depress the forward control pedal.
- To change to the reverse direction when operating with cruise control, depress the brake pedal to disengage the cruise control and stop the tractor; then depress the reverse control pedal.

DRIVING ON SLOPES

Refer to the SLOPE GAUGE on page 7 to help determine slopes where you may not operate safely.



WARNING: Do not mow on inclines with a slope in excess of 15 degrees (a rise of approximately 2-1/2 feet every 10 feet). The tractor could overturn and cause serious injury.



WARNING: Operate the tractor up and down slopes, never across slopes. Do not drive so that the tractor may tip over sideways .

Before operating the tractor on any slope, walk the slope to look for possible hazards such as rocks, mounds, ruts, stumps or other surface irregularities which could cause the tractor to overturn.

Back the tractor with implement up the steepest portion of each slope you intend to work. If the tractor cannot negotiate the slope in reverse, the slope is too steep to be worked.

Avoid turns when driving on a slope. If a turn must be made, turn **down** the slope. Turning up a slope greatly increases the chance of a roll over.

Avoid stopping when driving up a slope. If it is necessary to stop while driving up a slope, start up smoothly and carefully to reduce the possibility of flipping the tractor over backward.



WARNING: The hydrostatic transmission will not hold the tractor on a hill. Normal internal leakage in the transmission will allow the tractor to roll downhill. To avoid an accident and/or possible injury, engage the brake pedal lock.

STOPPING THE TRACTOR



WARNING: Always engage the brake pedal lock, push the PTO switch to the “OFF” position, lower the equipment and shut off the engine before dismounting.

- Fully depress the brake pedal to bring the tractor to a complete stop (and disengage the cruise control). Push downward on the parking brake/cruise control lever and hold the lever down while releasing the brake pedal. The lever should lock in the down position and the parking brake should be engaged.
- Depress the PTO switch knob to disengage the PTO.
- Turn the ignition switch to “STOP” and remove the key from the switch before dismounting.

PTO CLUTCH BREAK-IN (Before initial use ONLY)

Before operating the new clutch under load (mowing grass, etc.), perform the following break-in procedure:

1. Start and run the engine a few minutes to warm up.
2. With the mowing deck installed and the engine running at approximately 50% throttle, engage and disengage the clutch at ten second intervals (ten seconds ON - ten seconds OFF) five times. The engine choke may have to be pulled out slightly to accomplish this.
3. Increase the engine speed to 75% throttle and again engage and disengage the PTO clutch at ten second intervals five times.
4. Disengage the PTO and stop the engine.

OPERATING THE POWER TAKE-OFF (PTO) CLUTCH

IMPORTANT: NEVER engage the PTO clutch while its driven equipment is under load (e.g., mower deck lowered in grass, snow thrower lowered in deep snow, tiller lowered in soil). Premature wear and eventual failure of the PTO clutch and drive belts will result.

Operate the PTO clutch as follows:

1. Move the throttle control lever to approximately the mid throttle position.
2. Pull the PTO switch knob up to the “RUN” position.
3. Advance the throttle lever to the operating speed (full engine speed).
4. The operator must remain in the tractor seat at all times. If the operator should leave the seat without turning off the power take-off switch, the tractor’s engine will shut off.
5. **With key switch in “NORMAL MOWING” position ONLY:** The PTO clutch cannot be operated when the tractor is driven in the reverse direction. In the “NORMAL MOWING” position, the PTO clutch will automatically disengage when the reverse pedal is depressed. To re-engage the PTO clutch, release the reverse control pedal, move the PTO switch to the “OFF” position, then again pull the switch to the “RUN” position.

USING THE HITCH PLATE

Hitch type equipment must be hitched to the tractor only at the hole in the hitch plate (See Figure 4-1).

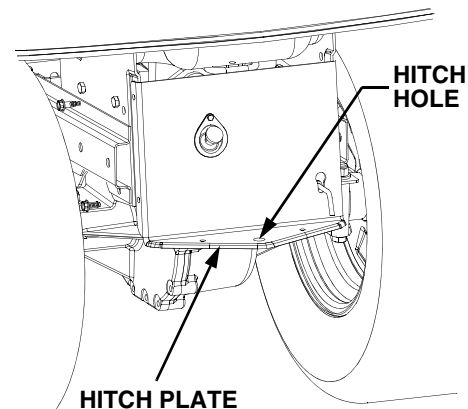

Figure 4-1

USING THE “REVERSE CAUTION MODE” KEY POSITION

NOTE: Mowing in reverse is not recommended.

The “REVERSE CAUTION MODE” position of the key switch module allows the machine to be operated in reverse with the blades (PTO) engaged. To utilize, proceed as follows:



WARNING: Use extreme caution while operating the tractor in the “REVERSE CAUTION MODE”. Always look down and behind before and while backing. Do not operate the tractor when children or others are around. Stop the tractor immediately if someone enters the area.

IMPORTANT: The operator *MUST* be seated in the tractor seat.

1. Start the engine and engage the PTO as previously instructed in this Operator’s Manual.
2. Turn the key from the “NORMAL MOWING” (Green) position to the “REVERSE CAUTION

MODE” (Yellow) position of the key switch module. Refer to Figure 4-2.

3. Depress the “REVERSE PUSH BUTTON” (Orange/Triangular Button) at the top/right corner of the key switch module. The red indicator light at the top/left corner of the key switch module will be “ON” while activated. Refer to Figure 4-2.
4. Once activated (indicator light “ON”), the tractor can be driven in reverse with the cutting blades (PTO) engaged.
5. Always look down and behind before and while backing to make sure no children are around.
6. After resuming forward motion, return the key to the “NORMAL MOWING” position.

IMPORTANT: The REVERSE CAUTION MODE *will remain activated until:*

- The key switch is turned to either the NORMAL MOWING or STOP position.
- The operator leaves the seat. Follow the previous instructions to re-activate.

KEY SWITCH MODULE

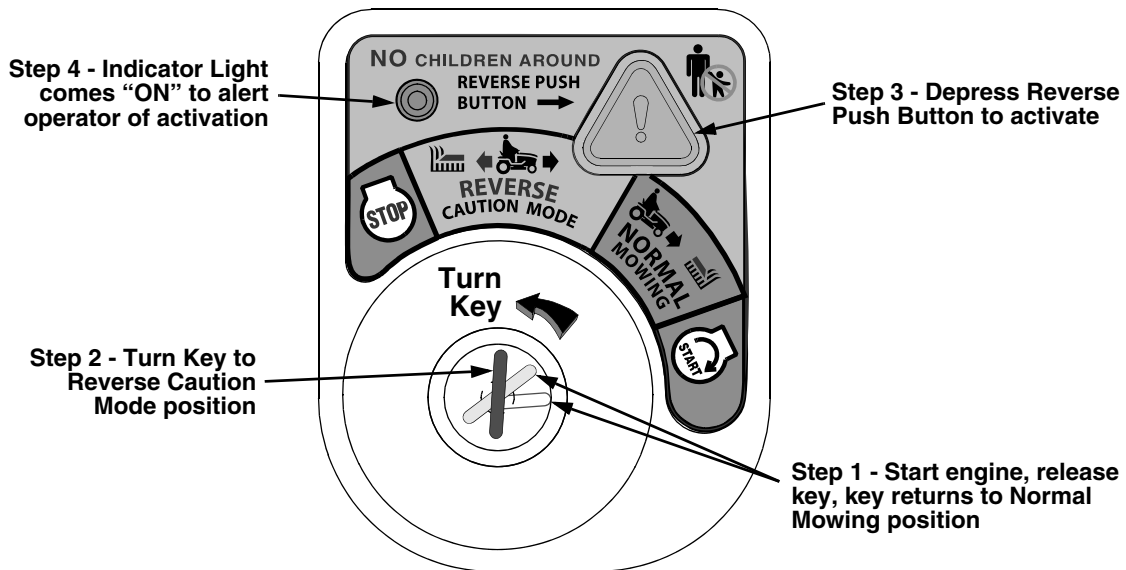

Figure 4-2

MOWING



WARNING: To avoid possible injury, do not allow anyone in the area opposite the discharge chute while mowing. Although the area has been supposedly cleared of foreign objects, small objects may be picked up and discharged by the mower. Never direct the discharge of material toward bystanders or allow anyone near the machine while in operation.

IMPORTANT: Do not engage the mower deck when lowered in grass. Premature wear and possible failure of the "V" belts and PTO clutch will result. Fully raise the deck or move to a non grassy area before engaging the mower deck.

For best results it is recommended that the first two laps should be cut with the discharge thrown towards the center. After the first two laps, reverse the direction to throw the discharge to the outside for the balance of cutting. This will give a better appearance to the lawn.

Do not cut the grass too short, as the mower will tend to scalp the grass. Short grass invites weed growth and yellows quickly in dry weather.

Mowing should be done with the engine at full throttle. Do not mow at high ground speed.

During certain times of the year and under some conditions, the mower may leave streaks of uncut grass.

Streaking may occur when attempting to mow heavy weeds and tall grass. Under these conditions it may be necessary to go back over the cut area a second time to get a clean cut.

The following practices will help eliminate streaking:

1. Mow the area more often so the grass doesn't get too tall and heavy.
2. Operate the tractor at full throttle and slower forward speeds.
3. Keep the blades sharp and replace the blades when worn.
4. Follow the mowing pattern shown in Figure 4-3.

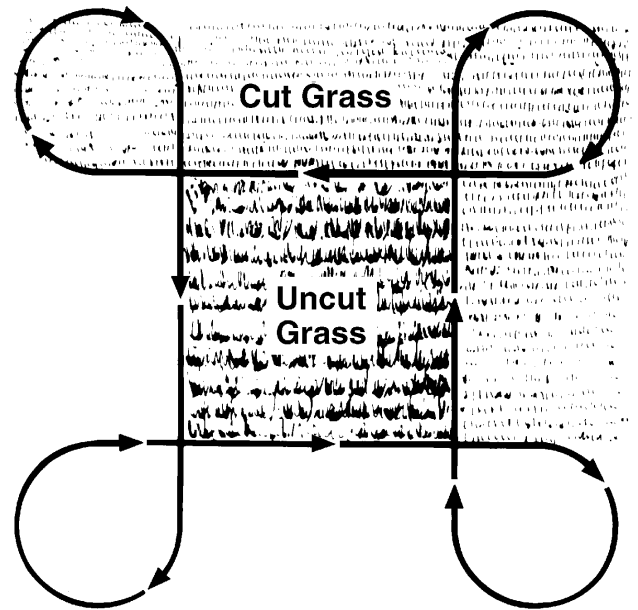

Figure 4-3

MOWING WITH MULCHING OPTION

1. **Do not cut wet grass.** For effective mulching do not cut wet grass. Wet grass sticks to the underside of the deck prevention proper mulching and dispersal of grass clippings.
2. **Cut no more than 1/3 the length of the grass.** When mulching long grass, it may be necessary to mow twice, lowering the deck another 1/3 of the length for the second cut, and perhaps cutting in a different pattern. Overlap the cut on each pass to help clean up any heavy clippings left on the lawn.
3. **Use a slow ground speed.** Adjust ground speed so clippings can be evenly dispersed into the lawn. When cutting heavy grass, it may be necessary to use a slower ground speed in order to get a well mulched cut.
4. **Always operate the tractor at full throttle.** To obtain the best cut and do the most effective job of mulching, the engine should be run at full throttle.
5. **Clean underside of deck.** Be certain to clean the underside of the deck often to avoid a buildup of grass clippings, which will prevent proper mulching.

Section 5: Maintenance and Adjustments

MAINTENANCE

CHECKING THE ENGINE

Refer to the Kohler Owner's Manual for all engine maintenance intervals, procedures, specifications and instructions.

CHECKING TRANSMISSION OIL LEVEL

NOTE: Check the oil level only while the engine is stopped and the tractor is level.

Check the oil level of the transmission case before each use to see that it is filled to the correct level. Before checking the transmission oil level, clean the area around the oil fill plug/dipstick to prevent debris from entering the transmission case. Always keep the oil level between the "FULL" and the "ADD" marks on the dipstick (See Figure 5-1). When checking the oil level, the dipstick must be withdrawn and wiped clean, then inserted all the way before being withdrawn for a true reading.

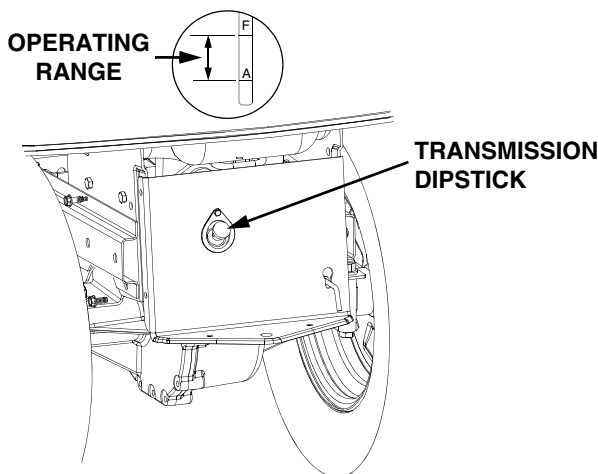

Figure 5-1

ADDING TRANSMISSION OIL



WARNING: Never overfill the transmission case. Damage or leakage may result if the oil level in the transmission case is below the "ADD" mark or over the "FULL" mark of the dipstick. For best results, fill to the "FULL" mark on the dipstick as opposed to adding a given quantity of oil. Always check the level on the dipstick before adding more oil.

Refer to the **LUBRICATION TABLE** for information regarding the proper type of oil to add to the transmission case.

1. Place the tractor on a level surface and engage the brake pedal lock. Stop the tractor engine and remove the ignition key.

2. Clean the area around the oil fill plug/dipstick to prevent debris from entering the transmission case.
3. Remove the oil fill plug/dipstick from the oil fill port and SLOWLY pour oil into the oil fill port. Fill the transmission case until the oil level reaches the "FULL" mark on the dipstick (Refer to Figure 5-1).
4. Reinstall the oil fill plug/dipstick securely into the oil fill port.

IMPORTANT: The oil fill plug/dipstick **must be installed securely into the fill port at all times when the engine is operating.**

GENERAL BATTERY INFORMATION



WARNING

- a. Battery posts, terminals and related accessories contain lead and lead compounds. **Wash Hands after handling.**
- b. Should battery acid accidentally splatter into the eyes or onto the skin, rinse the affected area immediately with clean cold water. If there is any further discomfort, seek prompt medical attention.
- c. If acid spills on clothing, first dilute it with clean water, then neutralize with a solution of ammonia/water or baking soda/water.
- d. NEVER connect (or disconnect) battery charger clips to the battery while the charger is turned on, as it can cause sparks.
- e. Keep all sources of ignition (cigarettes, matches, lighters) away from the battery. The hydrogen gas generated during charging can be combustible.
- f. As a further precaution, only charge the battery in a well ventilated area.

ALWAYS SHIELD EYES AND PROTECT SKIN AND CLOTHING WHEN WORKING NEAR BATTERIES.



BATTERIES CONTAIN SULFURIC ACID AND MAY EMIT EXPLOSIVE GASES. USE EXTREME CAUTION WHEN HANDLING BATTERIES. KEEP BATTERIES OUT OF THE REACH OF CHILDREN.

MAINTENANCE OF BATTERY

The tractor is shipped with a wet battery — the battery acid has already been added and the battery sealed. Although the battery is maintenance free, the following care should be taken when handling the battery and to assure its proper life cycle.

1. Spray the terminals and exposed wire with a battery terminal sealer, or coat the terminals with a thin coat of grease or petroleum jelly, to protect against corrosion.
2. Always keep the battery cables and terminals clean and free of corrosion.
3. Always keep the terminal covers in place over the battery terminals.
4. Avoid tipping. Even a sealed battery will leak electrolyte when tipped.

STORAGE OF THE BATTERY

1. When storing the tractor for extended periods, disconnect the negative battery cable. It is not necessary to remove the battery.
2. All batteries discharge during storage. Keep the exterior of the battery clean, especially the top. A dirty battery will discharge more rapidly.
3. The battery must be stored with a full charge. A discharged battery can freeze sooner than a charged battery. A fully charged battery will store longer in cold temperatures than hot.
4. Recharge the battery before returning to service. Although the tractor may start, the engine charging system may not fully recharge the battery.

COMMON CAUSES FOR BATTERY FAILURE

1. Overcharging
2. Undercharging
3. Loose and/or corroded connections
4. Excessive loads
5. Freezing of electrolyte

LUBRICATING THE STEERING HOUSING

The steering housing must be lubricated after every 25 hour of operation with Cub Cadet 251H EP grease, or an equivalent No. 2 multipurpose lithium grease.

Lubricating The Segment Gear Shaft

To access the lube fitting for the segment gear shaft, proceed as follows:

- Raise the hood using the hood latch at the bottom front of the hood.
- Working from the left side of the tractor at the front of the dash panel, remove the wing nut and carriage bolt securing the LH engine shield.
- Note the position of the LH shield, then maneuver the shield out of the tractor.

- Near the front of the steering housing, locate the lube fitting for the segment gear shaft. Apply lubrication through the lube fitting, using a pressure lubricating gun.
- Reposition the LH engine shield inside the tractor as noted earlier, and secure with the wing nut and carriage bolt.
- Close the tractor hood.

Lubricating The Steering Shaft.

Working beneath left side of the tractor frame, locate the lube fitting near the rear of the steering housing.

Using a pressure lubricating gun, apply grease through the steering shaft lube fitting.

LUBRICATING THE FRONT AXLE

The front axle must be lubricated after every 10 hour of operation with Cub Cadet 251H EP grease, or an equivalent No. 2 multipurpose lithium grease. There is a lube fitting at each end of the axle for lubricating the steering knuckles, and single lube fitting at the middle/bottom of the axle for lubricating the axle pivot bolt.

LUBRICATING THE MOWER DECK

After every 10 hours of operation and/or before putting the deck into winter storage, lubricate the spindle assemblies with 251H EP grease or an equivalent No. 2 multipurpose lithium grease. Also lubricate the two idler arms on the mower deck 251H EP grease or an equivalent No. 2 multipurpose lithium grease after every 10 hours of operation. Refer to the Lubrication Guide at the end of this section.

Every 50 hours, or twice yearly, lubricate the double pulley with 251H EP grease or an equivalent No. 2 multipurpose lithium grease. Also lubricate the front caster brackets and the all four gauge wheels after 50 hours of operation. Refer to the Lubrication Guide at the end of this section.

CLEANING THE MOWER DECK

Using The Deck Wash System



WARNING: When using the deck wash system, never engage the deck from any position other than the operator's seat of the tractor. Do not use an assistant or engage deck in the presence of any bystanders.

- Attach the nozzle adapter to a standard garden hose connected to a water supply.

- Move the tractor to an area within reach of the hose where the dispersal of wet grass clippings is not objectionable to you. Disengage the PTO, engage the parking brake, and stop the engine.
- Pull back the lock collar of the nozzle adapter and push the adapter onto one of the deck wash nozzles at either end of the mower deck. Release the lock collar to lock the adapter on the nozzle. See Figure 5-2.

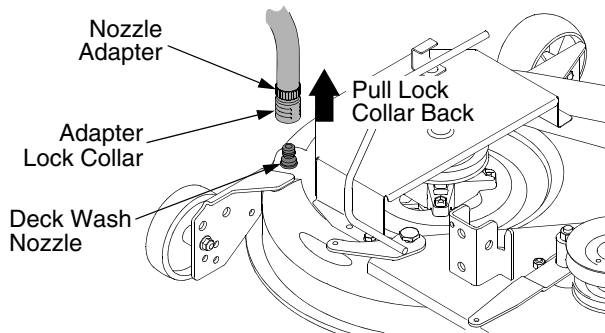

Figure 5-2

- Turn on the water supply.
- From the tractor operator's seat, start the engine and engage the PTO. Allow to run as needed. Disengage the PTO and stop the engine.
- Turn off the water supply.
- Pull back the lock collar of the nozzle adapter to disconnect the adapter from the nozzle.
- Repeat the previous steps to clean the deck using the nozzle at the other end of the deck.

Periodically remove the belt covers and remove any accumulated grass clippings from around the spindle pulleys and the deck belt.

TIRES

Keep the pneumatic tires properly inflated. Over-inflation will cause operator discomfort. Under-inflation will cause short tire life.

Improperly inflated tires will also affect the leveling of the mower deck and quality of cut.

Inflate the front and rear tires as shown in the following table:

Tire Size Pounds per Square Inch

Front Tires	
16 x 6.5-8	14
Rear Tires	
23 x 9.5-12	10

Always ensure that the tire valve caps are in place and tightened securely to prevent loss of air and to protect the valve core and stem.

Do not overload the tractor tires by mounting equipment on the tractor which exceeds the load capacity of the size of the tires on the tractor.

OFF SEASON STORAGE

If the machine is to be inoperative for a period longer than 30 days, the following procedures are recommended:



WARNING: Never store the tractor with fuel in the tank indoors or in poorly ventilated enclosures, where fuel fumes may reach an open flame, spark or pilot light as on a furnace, water heater, clothes dryer, etc.

IMPORTANT: Fuel left in the fuel tank during warm weather deteriorates and will cause serious starting problems.



WARNING: When adjusting the mower deck, be careful not to cut yourself on the sharp blades.

To prevent gum deposits from forming inside the engine's carburetor and causing possible malfunction of the engine, the fuel system must be either completely emptied, or the gasoline must be treated with a stabilizer to prevent deterioration.

1. If using a fuel stabilizer:
 - a. Read the product manufacturer's instructions and recommendations.
 - b. Add to clean, fresh gasoline the correct amount of stabilizer for the capacity of the fuel system.
 - c. Fill the fuel tank with treated fuel and run the engine for 2-3 minutes to get stabilized fuel into the carburetor.
2. If emptying the fuel system:



WARNING: Do not drain fuel when the engine is hot. Allow the engine adequate time to cool. Drain fuel into an approved container outdoors, away from open flame.

- a. Drain any large volume of fuel from the tank by disconnecting the fuel line from the in-line fuel filter near the engine.
- b. Reconnect the fuel line and run the engine until it starts to falter, then use the choke to keep the engine running until all fuel in the carburetor has been exhausted.
- c. Again disconnect the fuel line and drain any remaining gasoline from the system.

3. Remove the spark plug and pour one (1) ounce of engine oil through the spark plug hole into the cylinder. Crank the engine several times to distribute the oil. Replace the spark plug.
4. Clean the engine and the entire tractor thoroughly.
NOTE: We do not recommend the use of a pressure washer or garden hose to clean your tractor. They may cause damage to electrical components; spindles; pulleys; bearings; or the engine. The use of water will result in shortened life and reduce serviceability.
5. Lubricate all lubrication points shown on page 29.
6. Follow the battery storage instructions on page 23.
7. Protect the tires and seat from sunlight. Regularly check the tires to maintain proper inflation.

ADJUSTMENTS

ADJUSTING THE SEAT



WARNING: Do not adjust the seat when the tractor is moving. Adjusting the seat while the tractor is moving could cause the operator to lose control of the tractor.

Both seat arm rests can be rotated upward for mounting and dismounting the tractor, or for the personal comfort of the operator.

Before starting the tractor, adjust the seat forward or rearward to the most comfortable driving position. To reposition the seat, move the seat adjustment lever (See Figure 5-3) toward the left and slide the seat forward or rearward. Release the adjustment lever when the seat is comfortably positioned. Gently rock the seat forward or rearward to be sure the seat is locked in place.

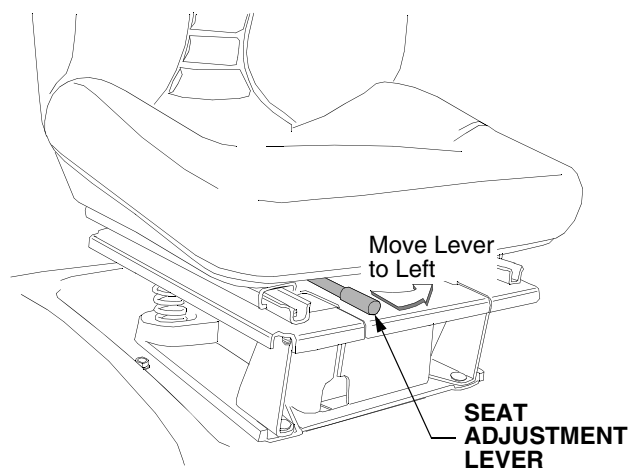

Figure 5-3

ADJUSTING LIFT ASSIST SPRING TENSION

The effort required to operate the implement lift handle can be varied by loosening or tightening the lift assist spring adjusting bolts on each side of the tractor (See Figure 5-4). The bolts can be accessed from the rear of the tractor, inside the left and right rear wheels. Turning each adjusting bolt clockwise will decrease the manual effort required for lifting attachments; turning counterclockwise will increase the effort needed to lift the attachment. It is recommended that both lift assist springs be adjusted to approximately the same tension.

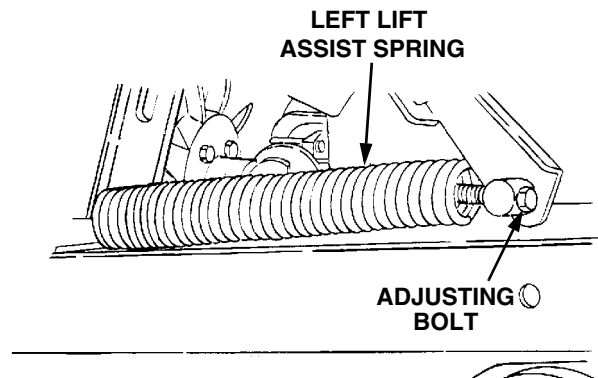

Figure 5-4

DECK LEVELING ADJUSTMENTS

The 54" mower deck is equipped with ground following front castor wheels and is designed to run on its wheels. However, to ensure even cutting, the mower deck should be properly leveled. The leveling procedure will result in the left and right blades having corresponding cutting-edge to ground measurements within 1/16 inch of each other. Also, the blades will have a downward tilt toward the front of the tractor of approximately 1/8 to 1/4 inch. To level the mower deck, proceed as follows:



WARNING: Before making any adjustments, place the PTO switch in the "OFF" position, engage the parking brake, turn the ignition key to the "OFF" position and remove the key from the switch. Disconnect the spark plug wires for additional safety. When handling the mower deck, be careful not to cut yourself on the sharp blades.

NOTE: Check the tires for proper inflation before making a leveling adjustment. To level the deck, the tractor and deck **MUST** be placed on a hard, level surface during adjustment.

SIDE TO SIDE LEVELING ADJUSTMENT

1. Position the tractor and mower on a hard, level surface.
2. The mower deck wheels should be installed in their uppermost position to prevent contact with the hard, level surface below. Refer to **CUTTING HEIGHT ADJUSTMENT**.
3. Raise the tractor implement lift handle to its highest setting. Carefully rotate the outer cutting blades so that they are positioned perpendicular to the tractor frame (See Figure 5-5). Then lower the deck to a mid-height setting using the tractor implement lift handle.

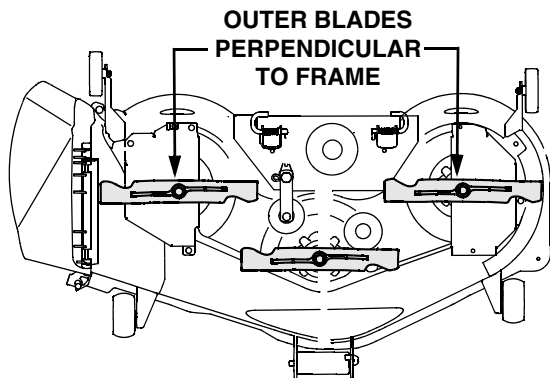
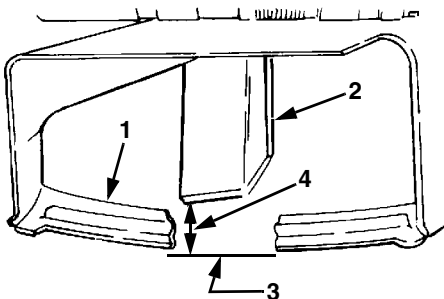

Figure 5-5

4. Referring to Figure 5-6, measure and record the distance from the hard, level surface to the outermost cutting edge of the right blade. Repeat this step for the left blade. If the two blade heights are not within 1/16 inch, note whether the right hand blade is lower or higher than the left blade, then proceed to steps 5, 6 and 7. If the two blade heights are within 1/16 inch, proceed to **FRONT TO BACK LEVELING ADJUSTMENT**.



- | | |
|-----------------|--------------------------|
| 1. Finger guard | 3. Hard Level Surface |
| 2. Blade | 4. Measure This Distance |

Figure 5-6

5. Lower the deck onto the hard, level surface.
6. Side-to-side leveling is obtained utilizing the adjustment ferrule and right hand lift link rod (Refer to Figure 5-7).

7. Loosen the upper jam nut on the lift link rod and turn away from the adjustment ferrule. Turn the lower lock nut upward (tighten) on the threads of the rod to raise the right side of the mower deck. Turn the lock nut down (loosen) on the threads to lower the right side of the mower deck (See Figure 5-7).

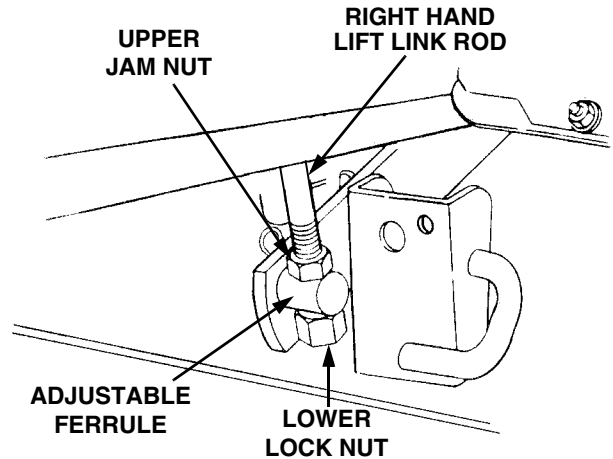

Figure 5-7

8. Raise the lift handle to the mid-height position and recheck the blade measurements described in step 4. If the blade measurements are not within 1/16 inch, repeat steps 5 and 7.
9. Tighten the upper jam nut against the adjustment ferrule after side-to-side leveling is completed.

FRONT TO BACK LEVELING ADJUSTMENT

1. Raise the deck to its highest position.
2. Position the mower blades so the ends of each blade point to the front and the rear of the tractor (See Figure 5-8). Lower the tractor implement lift handle to a mid-height setting.

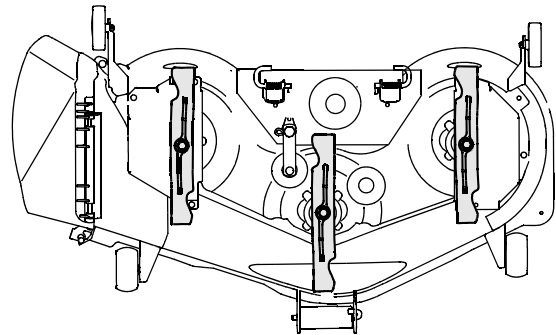

Figure 5-8

- Refer to Figure 5-9. Measure and record the distance from the front cutting edge to the ground (measurement A), and from the rear cutting edge to the ground (measurement B), for each of the blades. The front edge of each blade (measurement A) should be lower than its back edge (measurement B) by 1/8 to 1/4 inch.

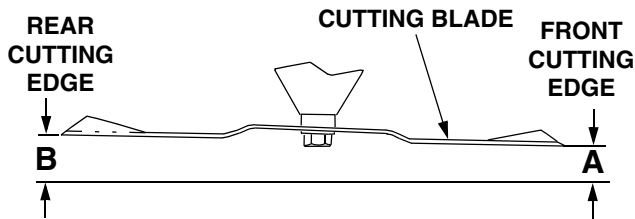

Figure 5-9

- From the front of the tractor, loosen the outer nuts on the deck front hanger rod, and turn them away from the inner nuts. (See Figure 5-10).

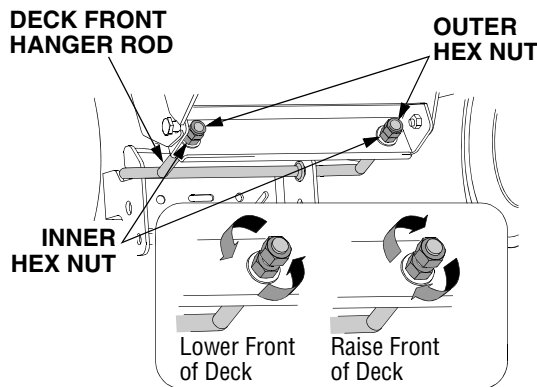

Figure 5-10

- If the front of the deck was too low, turn the inner hex nuts clockwise against the hanger bracket to shorten the front hanger rod and raise the front of the deck.
- If the front of the deck was too high, turn the hex nuts counterclockwise to lengthen the front hanger rod and lower the front of the deck.

IMPORTANT: The deck front hanger rod should be at the front of the slots of the front deck bracket. If one side of the rod is not at the front of its slot, turn the inner hex nut on that side until rod just touches the front of the slot. Then re-measure and re-adjust the front hanger rod as necessary.

- When the correct pitch of the deck is acquired, secure the inner hex nuts and tighten the outer hex nuts against the inner hex nuts to lock them in the adjusted position.
- Connect the spark plug wires if removed earlier.

GAUGE WHEEL ADJUSTMENT



WARNING: Before making any adjustments, place the PTO switch in the “OFF” position, engage the parking brake, turn the ignition key to the “OFF” position and remove the key from the switch. Disconnect the spark plug wires from the mower deck, be careful not to cut yourself on the sharp blades.

NOTE: Gauge wheel adjustment should be performed only AFTER the mower deck has been properly leveled.

IMPORTANT: Gauge wheels are intended to prevent scalping of the lawn, and are not designed to be used to set the cutting height. Do not run the deck on the gauge wheels.

To adjust the height of the gauge wheels, place the tractor on a firm and level surface. Refer to Figure 5-11, and proceed as follows:

- Place the tractor implement lift handle in the normally desired mowing height setting, then check the gauge wheels for contact or excessive clearance with the surface below.
- If the wheels contact the surface adjust as follows:
 - Raise the implement lift handle to its highest setting.
 - Remove the rear gauge wheels by removing the lock nuts and shoulder screws. Remove the lock nuts and shoulder screws fastening the front ball wheels to the deck gauge wheel brackets.

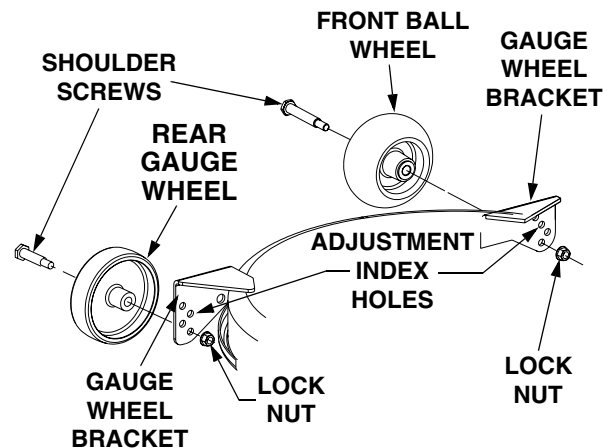

Figure 5-11

- Again place the tractor implement lift handle in the normally desired mowing height setting.

- d. Insert the shoulder screw with the rear gauge wheel into the adjustment index hole that provides approximately 1/2" clearance between the wheel and level surface. Secure with the lock nut.
 - e. Note the position of the index hole used; then install the other rear gauge wheel and the front ball wheels into the corresponding index hole of the other gauge wheel brackets.
3. If the gauge wheels have excessive clearance with the surface below, lower the wheels to the index hole that provides the approximate 1/2" clearance as described above.

IMPORTANT: All gauge wheels should be installed in the same relative adjustment index hole location in each of the gauge wheel brackets.

CUTTING HEIGHT ADJUSTMENT

The mower can be set in multiple positions. Proceed as follows:

NOTE: *If multiple positions are used while mowing, it may be necessary to adjust the gauge wheels for each setting to prevent scalping.*

1. Push the tractor implement lift handle down slightly and depress the button on the top of the lift handle.
2. Raise or lower the lift handle to obtain the desired mower deck cutting height.
3. Release the button when the desired mower position is obtained.

NOTE: *To return the mower deck to a specific position, note the position of the lift lever before raising or lowering the mower deck.*

LUBRICATION GUIDE



WARNING: The service life and reliability of any machine depends upon the care it is given. Proper lubrication is a very important part of that care. This lubrication schedule reflects the minimal requirements to maintain the equipment. More frequent inspections and maintenance is preferable.

NOTE: *We do not recommend the use of a pressure washer or garden hose to clean your unit. They may cause damage to electrical components; spindles; pulleys; bearings; or the engine. The use of water will result in shortened life and reduce serviceability.*

Using the lubrication illustration as a guide, make certain that all lubrication fittings are installed and functioning.

Be sure all fittings are free from dirt and paint so the lubricant is certain to enter the bearing.

Using a pressure lubricating gun, always force the lubricant through the full length of each bearing until it emerges at the end, carrying with it the worn lubricant and any dirt that may have entered the bearing.

Miscellaneous working parts not provided with lubrication fittings should be oiled regularly with a good grade of lubricating oil.

Always lubricate the tractor thoroughly before taking it to a remote location for a prolonged period of time.

Lubricant is cheap. Use plenty of it. Worn parts can be expensive to replace.

Keep your supply of lubricating oil and grease stored in clean containers, and covered to protect from dust and dirt.

Keep the lubricating gun nozzle clean and wipe dirt from the grease fittings before lubricating.

The symbols in the illustrations indicate the method of application and the hourly intervals to apply the lubricant.



Use a pressure lubricating gun and apply 251H EP grease (or equivalent No. 2 multi-purpose lithium grease) sufficient to flush out the old grease and dirt. Lubricate at the hourly intervals indicated on the symbols.



Dipstick, use to check engine and transmission oil before each use.

LUBRICATION GUIDE

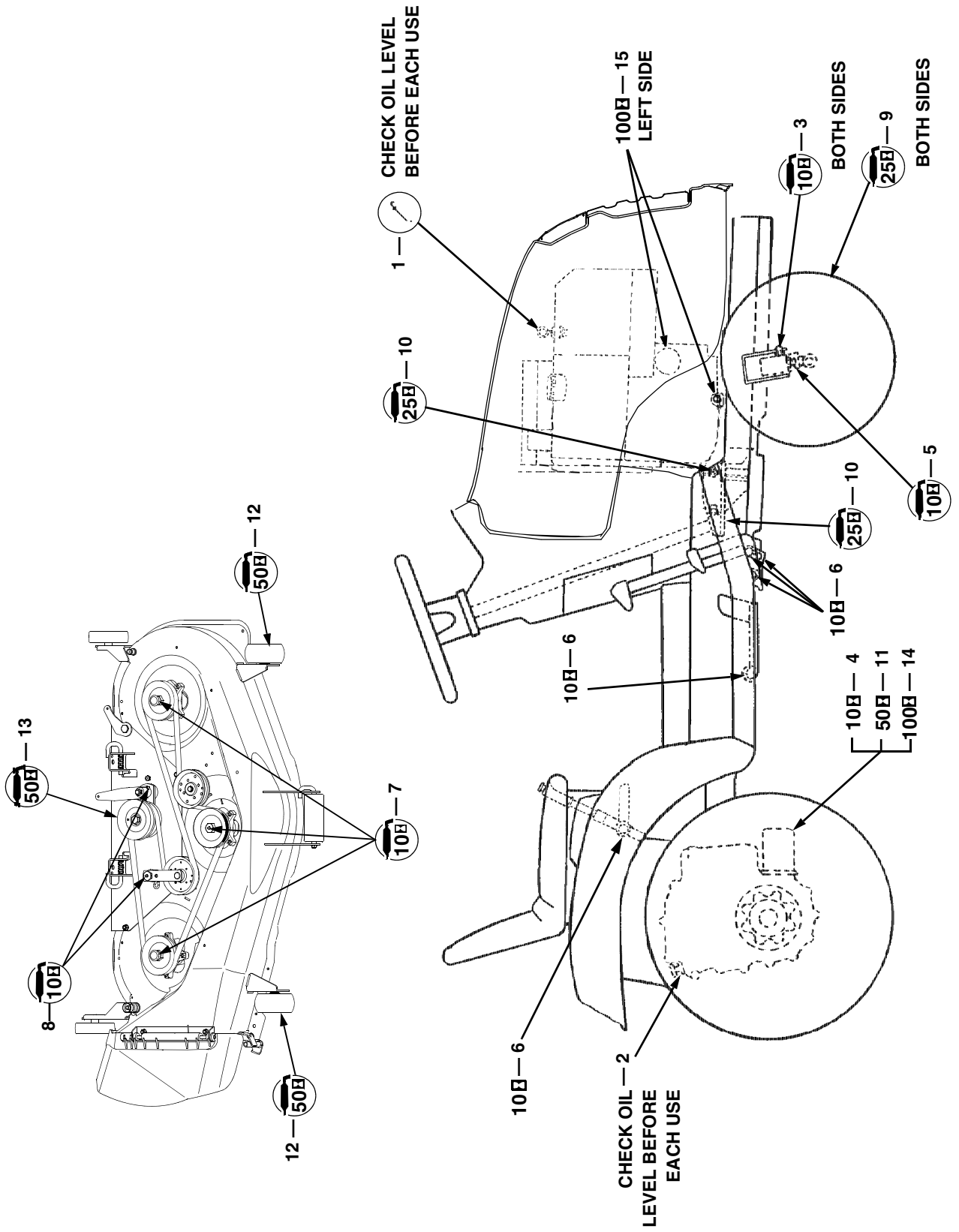

LUBRICATION TABLE

Point of Lubrication	Check at Hours	Change at Hours	Capacity	Anticipated Air Temperature	
				Above + 32°F	Below + 32°F
Engine crankcase	Check before each use	100	Approx. 4 pints	Cub Cadet Engine Oil SAE 10W30	Cub Cadet Engine Oil SAE 5W20 or 5W30
Hydro transmission and transaxle with filter	Check before each use	Add as needed	Approx. 6 qts	Cub Cadet Drive System Fluid Plus NOTE: <i>Cub Cadet</i> Drive System Fluid Plus is specially formulated for this application. If any other oil is used <i>Cub Cadet</i> will not be responsible for substandard performance. Failures due to use of improper fluid are not covered by warranty. For maximum protection, use <i>Cub Cadet</i> Drive System Fluid Plus.	
Steering knuckles and front axle pivot bolt	10			Use 251H EP grease or equivalent No. 2 multi-purpose lithium grease and apply two strokes (minimum) or sufficient grease to flush out old grease and dirt.	
Front wheel bearings	25			Two strokes (minimum) of the lubricator using 251H EP grease or equivalent No. 2 multi-purpose lithium grease.	
Steering housing	25			Two strokes (minimum) of the lubricator using 251H EP grease or equivalent No. 2 multi-purpose lithium grease.	
Deck spindles	10			Two strokes (minimum) of the lubricator using 251H EP grease or equivalent No. 2 multi-purpose lithium grease.	
Spindle belt idler arm	10			Two strokes (minimum) of the lubricator using 251H EP grease or equivalent No. 2 multi-purpose lithium grease.	
Deck Double Pulley	50			Use 251H EP grease or equivalent No. 2 multi-purpose lithium grease. Do not over lubricate.	
Deck gauge wheels	50			Use 251H EP grease or equivalent No. 2 multi-purpose lithium grease.	
Foot and lift control pivot points	10			Use a liberal amount of high grade lubricating oil.	

MAINTENANCE CHART

Operation to be performed	Before each use	10 hours or once a month	Every 25 hours	50 hours or twice a season	100 hours or yearly	Before storage
Check engine oil level	X					
Fill fuel tank	X					
Change engine oil & oil filter			After first 25 hours, engine oil only		Every 100 hours thereafter X	
Check transmission oil level	X					
Replace transmission oil filter		After first 10 hours X		After first 50 hours X	Every 100 hours thereafter X	
Clean & re-oil foam air precleaner			X			
Check battery terminals and case		X				X
Grease front axle pivot bolt		X				X
Grease steering knuckles		X				X
Retorque rear wheel lug nuts		After first 10 hours X				X
Replace air cleaner paper cartridge					More often under dirty conditions X	
Check spark plugs					X	X
Clean engine air inlet screen.	X					
Clean cylinder heads and cylinder block					More often under dirty conditions X	
Grease steering housing			X			X
Grease front wheel bearings			X			X
Drain fuel						X
Check pivot bar adjustment bolts				X		
Grease deck spindles and spindle belt idler arm		X				X
Lube deck double pulley				X		X
Lube gauge wheels				X		X
Lubricate all foot and lift control pivot points		X				X

NOTE

Maintenance information for optional equipment may be found in the manual which is included with that specific piece of equipment.

Section 6: Service

This section contains information for the various adjustments and service procedures on the tractor. Refer to the Kohler engine manual for engine service instructions and intervals, but use the instruction in the following sub-section when draining the engine crankcase.

DRAINING THE ENGINE OIL

NOTE: The engine oil should be changed after the first 25 hours of operation. The oil and oil filter should be changed after every 100 hours of operation.



WARNING: If the tractor has recently been operated, the engine and surrounding areas may be hot. Use caution not to burn yourself when draining the oil from the crankcase, and changing the oil filter.

IMPORTANT: The oil filter should be changed at every oil change.

Run the engine for a few minutes to allow the oil in the crankcase to warm up. Warm oil will flow more freely and carry away more of the engine sediment which may have settled at the bottom of the crankcase. Use care to avoid burns from hot oil.

While the engine oil is warm, proceed as follows:

1. Place the tractor on a level surface and engage the parking brake. Stop the tractor engine and remove the ignition key.
2. Clean around the base of the oil filter, oil level dipstick, dipstick tube, and the oil filler cap to prevent debris from entering the crankcase.
3. Unseat the plastic dust cap from the engine oil drain valve. To prevent loss of the cap, do not remove the cap's retaining ring from the drain valve (Refer to Figure 6-1). Remove the dipstick and oil fill cap.
4. Push the oil drain tube (supplied in owner's manual package) onto the end of the drain valve. Place an appropriate container below the open end of the tube to collect the old oil.
5. Pinch the tabs on the oil drain valve, then pull outward to begin draining oil. See Figure 6-1.
6. After the oil has finished draining, push the end of the oil drain valve back in, until the tabs click into place. Re-cap the end of the oil drain valve to keep debris from entering the drain port.

7. Clean the drain valve and push the plastic dust cap onto the valve.

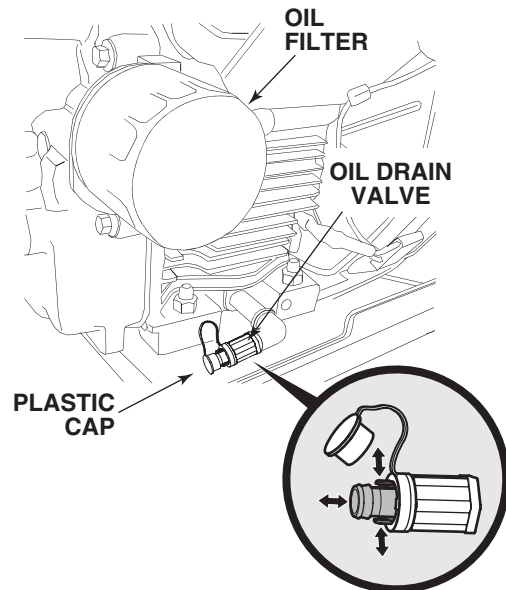

Figure 6-1

HYDROSTATIC DRIVE OIL FILTER



WARNING: Never overfill the transmission case. Damage or leakage may result if the oil level in the transmission case is below the "ADD" mark or over the "FULL" mark of the dipstick. For best results, fill to the "FULL" mark on the dipstick as opposed to adding a given quantity of oil. Always check the level on the dipstick before adding more oil.

Refer to the **MAINTENANCE CHART** for information regarding the frequency of the hydrostatic transmission oil filter replacement. The filter, part number 923-3014, can be obtained from your *Cub Cadet* dealer.

Refer to the **LUBRICATION TABLE** for information regarding the oil capacity and the proper type of oil to pour into the transmission case.

1. Place the tractor on a level surface and engage the brake pedal lock. Stop the tractor engine and remove the ignition key.
2. Clean the area around the transmission drain plug to prevent debris from entering the transmission case. Remove the drain plug and allow the transmission oil to drain into a clean container

having a capacity of more than 6 quarts. Reinstall the drain plug (See Figure 6-2).

IMPORTANT: If the transmission oil is to be re-used, cover the container holding the drained oil to prevent contamination. Contaminated transmission oil can damage the hydro transmission.

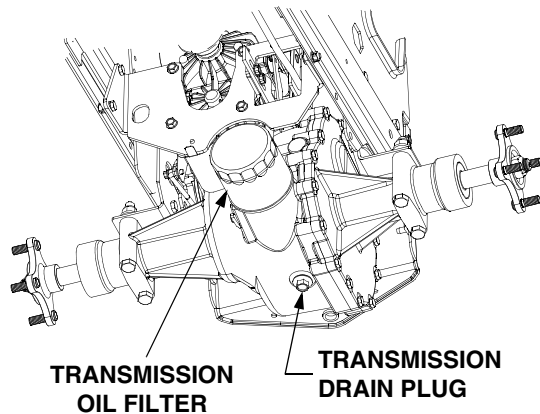

Figure 6-2

3. Clean around the base of the transmission oil filter and remove the filter by turning it counterclockwise (Refer to Figure 6-2).
4. Apply a light coating of clean transmission oil to the gasket of the new filter. Install the filter by turning it clockwise, by hand, until the gasket contacts the filter base on the transmission housing; then tighten the filter an additional 1/2 turn.
5. Clean the area around the transmission oil fill plug/dipstick to prevent debris from entering the transmission case.
6. Remove the oil fill plug/dipstick from the oil fill port and SLOWLY pour oil into the oil fill port. Fill the transmission case until the oil level reaches the "FULL" mark on the dipstick (Refer to Figure 5-1).
7. Reinstall the oil fill plug/dipstick securely into the oil fill port.
8. Start the engine and allow it to run for a few minutes. Shut the engine off, then check for leaks and re-check the oil level in the transmission case.

WARNING: The oil fill plug/dipstick must be installed securely into the fill port at all times when the engine is operating.

ADJUSTING THE BRAKES

During normal operation of this tractor, the brakes are subject to wear and will need periodic examination and adjustment.

To check the brake adjustment, position the tractor on a firm and level surface. Stop the tractor engine and remove the ignition key. Pull and lock the transmission release lever in the "TRANSMISSION RELEASED" position. Perform the following checks:

1. Engage the brake pedal lock. If the tractor can be pushed forward or rearward, the braking force must be increased.
2. Release the brake pedal lock. If the tractor cannot be pushed forward or rearward, the braking force must be decreased.

To adjust the braking force proceed as follows (Refer to Figure 6-3):

1. Place the tractor on a level surface with the brake pedal lock disengaged. Stop the tractor engine and remove the ignition key.
2. Working from the under right side of the tractor, at the brake pedal shaft, locate the front threaded end of the brake rod:
 - Remove the internal cotter pin from the brake rod adjustment ferrule and withdraw the ferrule from the brake cam. See Figure 6-3.
 - Loosen the hex flange insert lock nut from against the ferrule.

To increase the braking force —

Turn the ferrule clockwise (inward) one full turn at a time until the ferrule can be inserted into the brake cam while applying a **minimal tension** on the spring.

To decrease the braking force —

Turn the ferrule counterclockwise (outward) one full turn at a time until the ferrule can be inserted into the brake cam while applying a **minimal tension** on the spring.

3. Turn the ferrule counterclockwise (outward) one full turn to release the slight spring tension. Tighten the hex flange insert lock nut against the ferrule, then insert the ferrule into the brake cam and secure with the internal cotter pin.

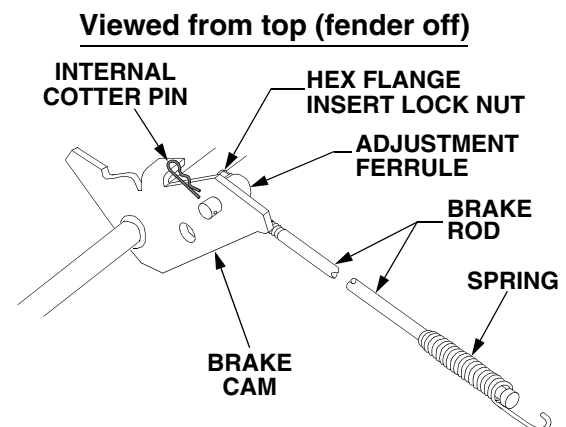

Figure 6-3

Recheck the brake adjustment to ensure proper brake operation before operating the tractor. If brake rod adjustment does not correct the problem, see your authorized *Cub Cadet* dealer.

WHEEL ALIGNMENT

The front wheels should toe-in approximately 1/8 to 1/4 inch, as measured across dimensions A and B shown in Figure 6-4.

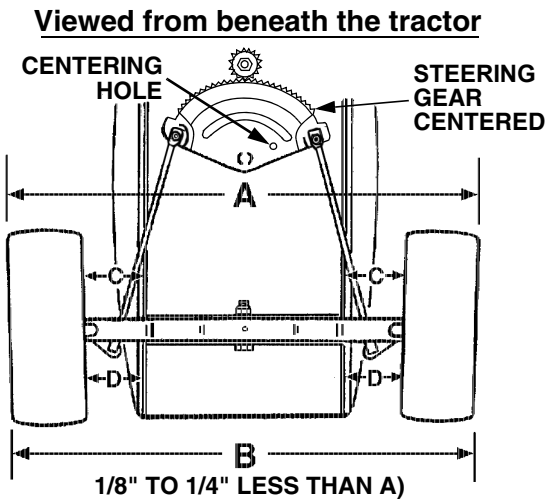

Figure 6-4

FRONT WHEEL ADJUSTMENT



WARNING: Place the tractor on a firm and level surface.

To adjust the toe-in, proceed as follows:

1. Check the steering gear to ensure it is in the centered position. The hole in the steering segment gear will align with the hole in the steering housing (See Figure 6-4). **NOTE:** A 5/16" pin can be used in the alignment holes to assure the steering segment is centered.
2. Mark the front *horizontal* diameter of both front wheels at the same spot on each wheel—preferably the inner bead flange of the wheel rims. Mark the rear horizontal diameter of both front wheels in the same manner.
3. Measure the distance between the bottom edges of the tractor frame channels and the marks on the front of each wheel (See measurement D in Figure 6-4). These two measurements should be equal.
- Measure the distance between the frame and the marks on the rear of each front wheel (See measurement C in Figure 6-4). Measurement D should be approximately 1/16 to 1/8 inch less than measurement C on each side of the tractor.

4. Loosen the jam nuts from the ball joints (See Figure 6-5).
5. Disconnect the front ball joints from the steering arms by removing the hex lock nuts (Refer to Figure 6-5). Manually move each wheel to achieve the required toe-in *and* equal D measurements.

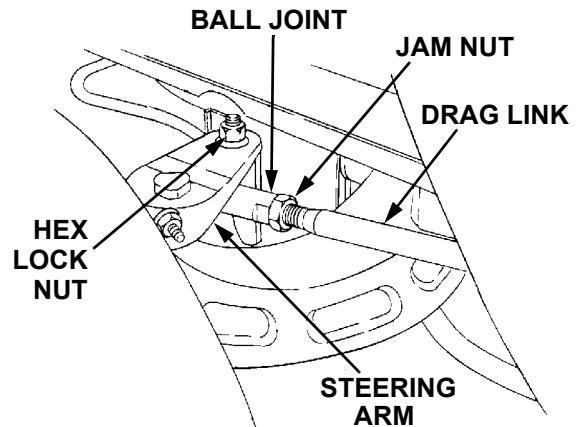

Figure 6-5

6. Making sure not to move the steering gear or either wheel, turn the ball joint in or out on each drag link as necessary to align with the hole in each steering arm.
7. Reinstall the ball joints in the steering arms and secure with the hex lock nuts. Tighten the jam nuts against the ball joints.

PIVOT BAR ADJUSTMENT



WARNING: The tractor should be checked every 50 hours of operation for play between the frame axle channel and the pivot axle.

Check and adjust the pivot axle as follows:

1. Raise the front of the tractor and set it on jack stands, so the front wheels are suspended above the ground.



WARNING: For safety, block the rear wheels to prevent the tractor from rolling and tipping or sliding the jack stands.

2. Pivot the ends of the axle up and down to check for binding. If the axle is binding, loosen the lock nuts (See Figure 6-6) until binding is eliminated.

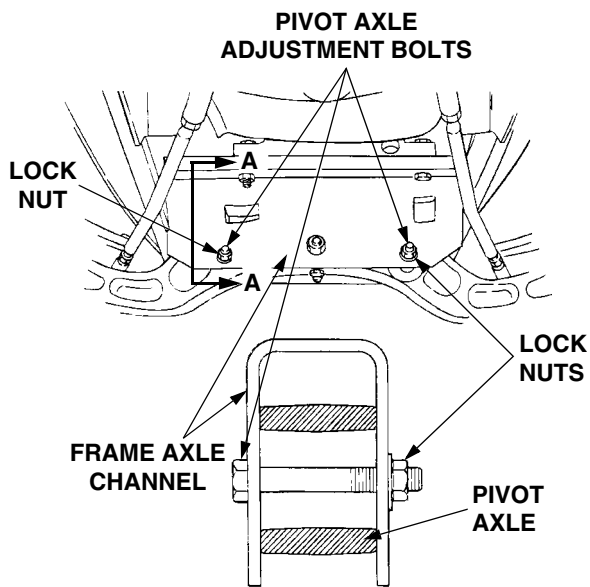

SECTION A-A
Figure 6-6

3. Grasping the ends of the pivot axle, attempt to move each end of the axle forward and rearward to check for side play between the axle and frame channel. If play is present, gradually tighten the lock nuts until play is minimized.
4. Repeat steps 2 and 3 until minimum play without binding is achieved.
5. Raise the front of the tractor, remove the jack stands, and lower the tractor to the ground. Remove the blocks from the rear wheels.

HYDROSTATIC NEUTRAL ADJUSTMENT

The following adjustments will be necessary if the tractor creeps forward or rearward when neither the forward nor reverse pedals are depressed.

Checking the Transmission Neutral Setting

To check and adjust the transmission neutral setting, proceed as follows:

1. Drive the tractor for approximately 5-10 minutes to warm up the transmission, then stop the engine and engage the parking brake.



WARNING: Place the tractor on a firm and level surface and chock the front wheels before raising the rear wheels from the ground. Use jack stands to support the rear of the tractor when raised.

2. Raise the rear of the tractor, so that the rear tires are at least one inch above the surface, and set it on jack stands. Make certain the jack stands are positioned to balance the tractor and prevent tipping.



WARNING: The operator presence safety circuit will stop the engine if the seat is empty when the brake pedal is released. If an assistant is seated when adjusting the neutral setting, use extreme caution to prevent the tractor from tipping or rolling. Similar precautions should be taken with any other method of over-riding the safety circuit, such as placing a weight in the seat. Never operate the tractor with the safety circuit disabled.

3. Carefully start the tractor engine and release the parking brake. Observe both rear wheels for rotation in either direction.
4. If wheel rotation is observed, refer to Figure 6-7 and adjust the neutral setting as follows:
 - a. Disconnect the rear control rod (2) from the control arm (5) by removing the internal cotter pin (10) from the control arm pin (6).
 - b. If wheel rotation stops when the rod is disconnected, check and readjust the control rod per the instructions below.
 - c. If wheel rotation continues, loosen the two hex washer head tapp screws (4) securing the neutral return adjustment bracket (9).
 - d. If the rotation is in the *forward* direction, slide the neutral return adjustment bracket w/ centering pin (8) rearward until the wheels just begin to rotate in the *reverse* direction. Then slowly slide the neutral return adjustment bracket w/centering pin slightly forward until wheel rotation stops.
 - e. If the rotation is in the *reverse* direction, slowly slide the adjustment bracket w/centering pin slightly forward until rotation stops.
 - f. Carefully tighten the hex wash. hd. tapp screws (4), making certain the neutral return adjustment bracket does not move.
 - g. Stop the engine and **engage the parking brake.**

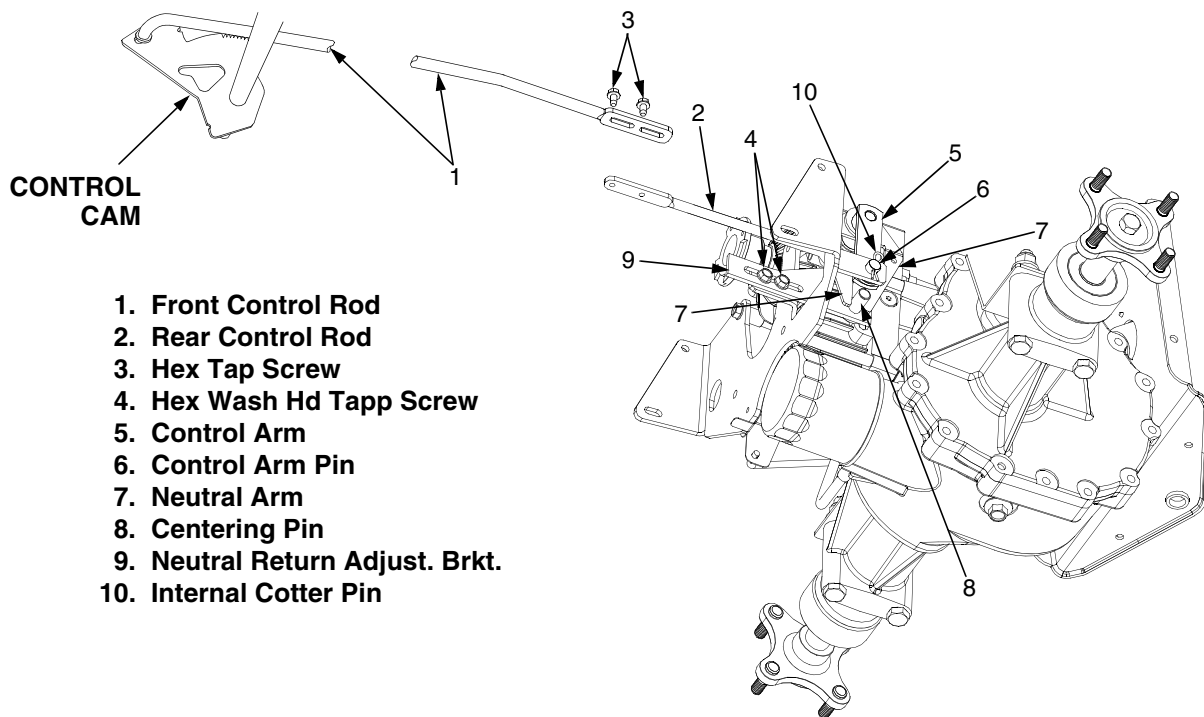

1. Front Control Rod
2. Rear Control Rod
3. Hex Tap Screw
4. Hex Wash Hd Tapp Screw
5. Control Arm
6. Control Arm Pin
7. Neutral Arm
8. Centering Pin
9. Neutral Return Adjust. Brkt.
10. Internal Cotter Pin

Figure 6-7

Adjusting the Control Rod

After completing the previous steps (1 thru 4) for checking neutral setting, refer to Figure 6-7 and adjust the control rod as follows:

NOTE: The brake pedal lock *MUST* be engaged to properly adjust the control rod.

1. Loosen, but do not remove, the hex tap screws (3) that fasten the front and rear control rods together.
2. While making certain to not move the front control rod (1), control cam, or control arm (5), slide the rear control rod (2) in the direction necessary to directly align its hole with the control arm pin (6).
3. Slide the rear control rod onto the control arm pin and secure with the internal cotter pin (10), then tighten the hex tap screws(3). Make sure to maintain the adjusted position of the control rods when tightening the screws.
4. Raise the rear of the tractor, remove the jack stands and lower the tractor.

COMMON CAUSES FOR BATTERY FAILURE

1. Overcharging
2. Undercharging
3. Loose and/or corroded connections
4. Excessive loads
5. Freezing of electrolyte

*** These causes do not constitute warranty in the event of a battery failure.**

BATTERY REMOVAL OR INSTALLATION



WARNING: Battery posts, terminals and related accessories contain lead and lead compounds. Wash Hands after handling.

When removing the battery, disconnect the battery cables in the following order to avoid arcing and the resulting sparks:

Battery Removal:

1. Disconnect the Negative cable.
2. Disconnect the Positive cable.

When installing the battery, connect the battery cables in the following order:

Battery Installation:

1. Connect the Positive cable.
2. Connect the Negative cable.

To replace the battery, proceed as follows:

1. Remove the negative cable from the negative terminal of the battery, then remove the positive cable from the positive terminal.
2. Remove the hex screw securing the LH side of the holddown rod to the battery tray (Refer to Figure 6-8).
3. Note which battery tray hole the RH side of the holddown rod is hooked into.
4. Rotate the holddown rod upward, over and around the battery to unhook from the battery tray.
5. Loosen the hose clamp and pull the drain tube from the battery.

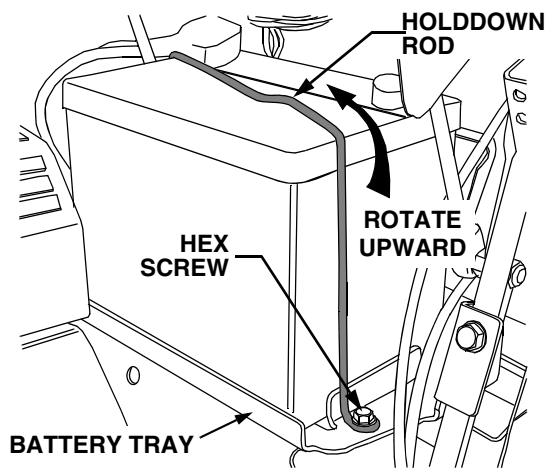

Figure 6-8

6. Lift the battery out off the battery tray and remove from the tractor.
7. Position the new battery and lower into the battery tray.
8. Install the drain tube onto the battery and secure with the hose clamp.
9. Hook the holddown rod into the previously noted battery tray hole, then rotate the rod around and over the battery.
10. Align the LH side of the holddown rod with the hole in the battery tray and secure with hex screw remove earlier.
11. Connect the positive cable to the positive terminal of the battery, then connect the negative cable to the negative terminal.

CHARGING THE BATTERY

Test and, if necessary, recharge the battery after the tractor has been stored for a period of time.

- A voltmeter or load tester should read 12.6 volts (DC) or higher across the battery terminals.
- Charge the battery with a 12-volt battery charger at a **MAXIMUM** rate of 10 amps.

Voltmeter Reading	State of Charge	Charging Time
12.7	100%	Full Charge
12.4	75%	90 Min.
12.2	50%	180 Min.
12.0	25%	280 Min.

HEADLIGHTS

Refer to **SPECIFICATIONS** when replacement of head lamp bulbs is necessary.

Replace headlight bulbs as follows: (See Figure 6-9)

1. Fully raise the hood of the tractor.

2. Unplug the wire harness leads from the headlight socket terminals. *Note which wire connects to each terminal before disconnecting.*
3. Rotate the socket assembly approximately 1/4 turn to align the socket tab with the reflector housing notch; then withdraw the bulb and socket assembly from the reflector housing.
4. Push the bulb inward and turn counterclockwise to remove from the socket.

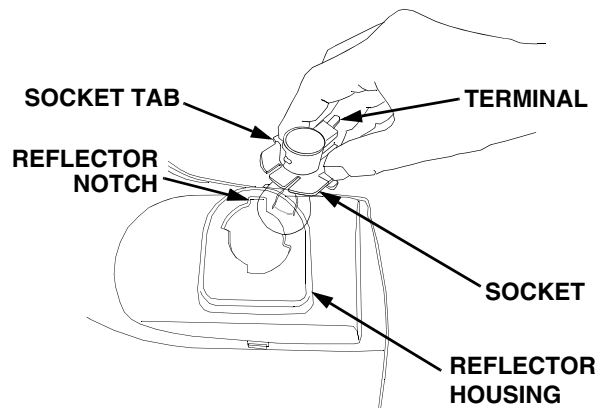

Figure 6-9

5. Align a locking post of the bulb base with the notch in the socket, then push the bulb inward and turn clockwise to lock
6. Align the socket tab with the notch of the reflector housing; then push the socket inward and turn as necessary to lock the socket in the housing;
7. Connect the wire harness leads to the appropriate socket terminals.

FUSES

Always use the same capacity fuse for replacement. Refer to **SPECIFICATIONS**. If the electrical system does not function, check the fuses.

To replace a fuse, pull the old fuse from the fuse holder and install the new fuse.

MOUNTING TIRES ON THE RIM



WARNING: Do not mount a tire unless you have the proper equipment. Do not inflate the tire above the recommended pressure. Do not stand over the tire assembly when inflating. Accidental over inflation could cause an explosive separation of the tire and rim, which could result in serious injury of death.

After mounting a new or old tire on the rim, inflate it to 20 pounds (maximum) pressure to seat the tire bead on the rim flange. Then deflate the tire to the correct operating pressure.

NOTE: After the first 10 hours of operation, check and re-torque the rear wheel lug nuts (both sides) to 35 ft-lbs to make sure they are properly tightened.

REMOVAL OF DECK



WARNING: Before removing the mower deck, place the PTO switch in the “OFF” position, engage the parking brake, turn the ignition key to the “OFF” position and remove the key from the switch. Disconnect the spark plug wire for additional safety. When handling the mower deck, be careful not to cut yourself on the sharp blades.

1. Position the tractor and mower deck on a firm, level surface.



WARNING: The deck idler arm lever is spring loaded. Release it slowly.

2. Lower the mower deck by moving the implement lift handle to its lowest setting. Disengage the deck idler arm lever from its stop bracket and release the spring tension by rotating the lever out and rearward (See Figure 6-10).

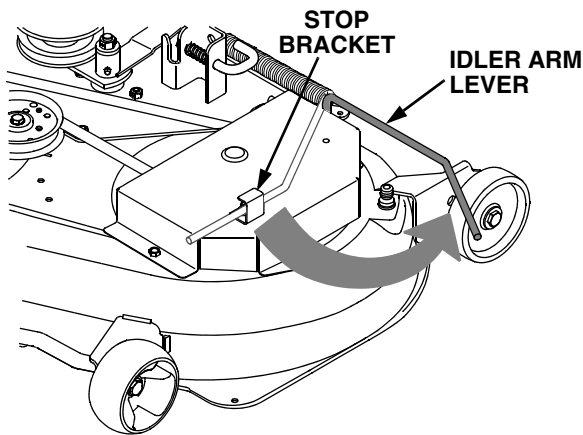

Figure 6-10

3. Remove the rearward end of the PTO belt from the upper pulley of the deck center double-pulley (Refer to Figure 6-11).

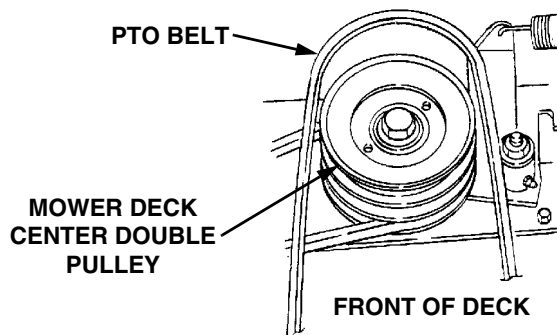

Figure 6-11

4. Engage the deck idler arm lever back into its stop bracket (See Figure 6-12).

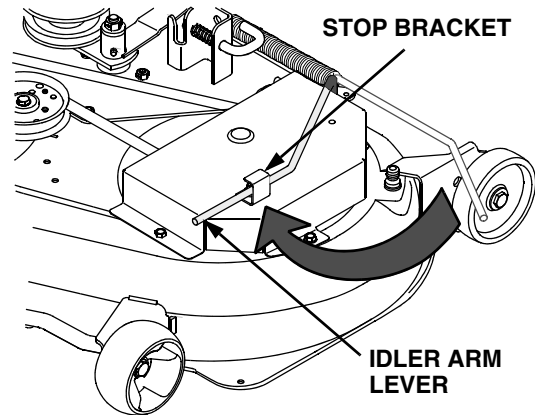

Figure 6-12



WARNING: The exhaust system is HOT. To avoid personal injury, allow the engine and exhaust system to cool before proceeding with the following PTO belt removal instructions.

5. Open the tractor hood. From the front of the tractor, lift the two sides of the belt up and maneuver the PTO belt over and off the front of the PTO clutch pulley on the front of the engine. Lower the belt down between the front of the PTO pulley and the engine heat shield (See Figure 6-13).

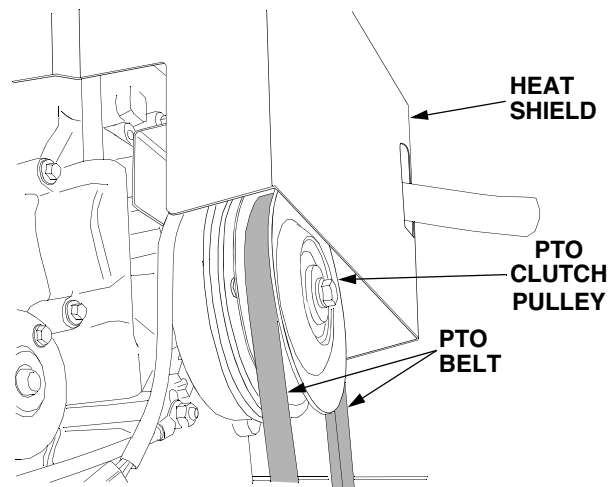

Figure 6-13

6. Pass the PTO belt downward, inside the tractor frame, until the belt is below the two tractor front lower pulleys and pull the belt clear of the tractor (See Figure 6-14).

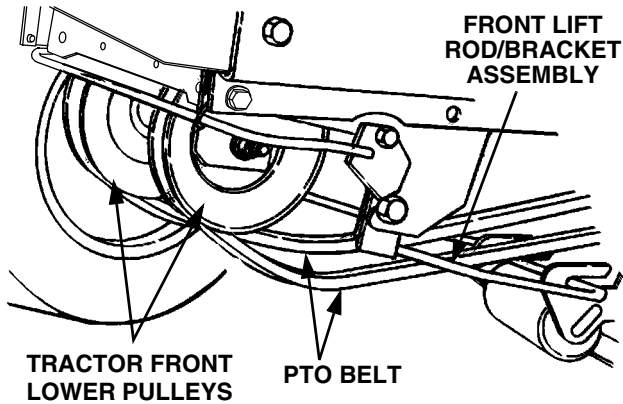

Figure 6-14

7. Pull the deck support pins outward, turn downward and release so both spring-loaded pins are held in the disengaged position against the outer surface of the deck brackets (Refer to Figure 6-15).

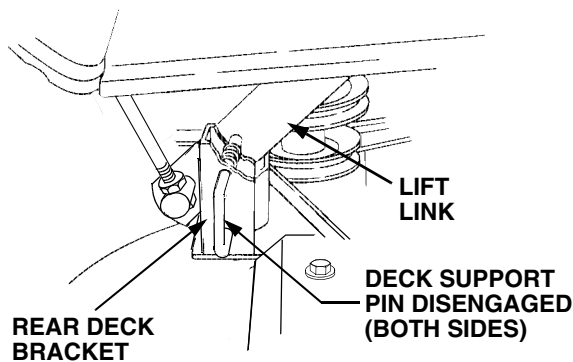

Figure 6-15

8. Raise the tractor implement lift handle to its highest setting. Roll the mower deck forward until the front lift rod slides up and out of the openings of both front roller bracket slots. Manually lift the rod out of the slots if necessary (Refer to Figure 6-16).
9. Raise the front lift rod upward and slide the mower deck rearward. Lower the front lift rod so it rests on the front roller bracket of the deck, forward of the slots (See Figure 6-16).

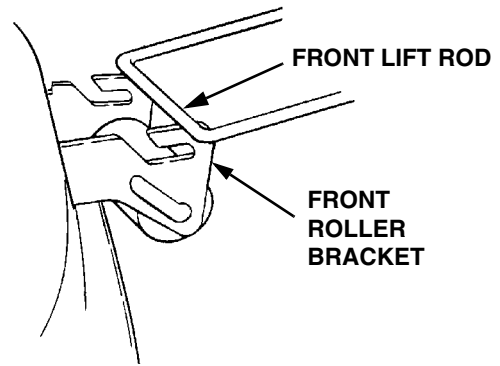

Figure 6-16

10. From the front of the tractor, push downward and hold the tractor quick-attach rod. Pull the front lift rod/bracket assembly forward to release the shoulder bolts on each side of the bracket from the left and right tractor latch receivers. Release the tractor quick-attach rod (Refer to Figure 6-17).

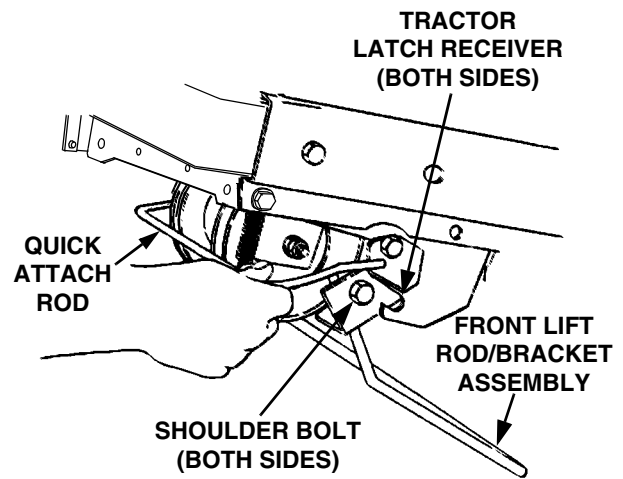

Figure 6-17



WARNING: To avoid possible equipment damage, make sure that the tractor implement lift handle is raised to its highest setting before sliding the deck out from under the tractor.

NOTE: To aid in sliding the deck out from under the tractor, turn the steering wheel as needed to obtain more room as you maneuver the deck from under the tractor.

11. With the tractor implement lift handle raised to its highest setting, slide the deck to the right and out from under the tractor.
12. Connect the spark plug wires and close the tractor hood.

BLADE CARE



WARNING: Before performing any maintenance, place the PTO switch in the "OFF" position, engage the parking brake, turn the ignition key to the "OFF" position and remove the key from the switch to avoid accidental starting and injury. When servicing the mower deck, be careful not to cut yourself on the sharpened blades.

The cutting blades must be kept sharp at all times.

IMPORTANT: Sharpen the cutting edges of the blades evenly so that the blades remain balanced and the same angle of sharpness is maintained.

If the cutting edge of a blade has already been sharpened many times, or if any metal separation is present, it is recommended that new blades be installed. New blades are available at your authorized dealer.

When removing the blades, use a 1-1/8 inch wrench to hold the hex head of the spindle bolt when loosening the hex nut securing the blade. A block of wood may be placed between the deck housing and the cutting edge of the blade to help in breaking loose the hex nut securing the blade (Refer to Figure 6-18).

After replacing the blades, apply grease the exposed threads at the bottom of the spindle bolts to prevent rust buildup.

When replacing the blades, be sure they are installed so that the wind wings are pointing upward toward the top of the deck housing. Tighten the nuts to 90 to 110 ft-lbs. (122 to 149 N·m).

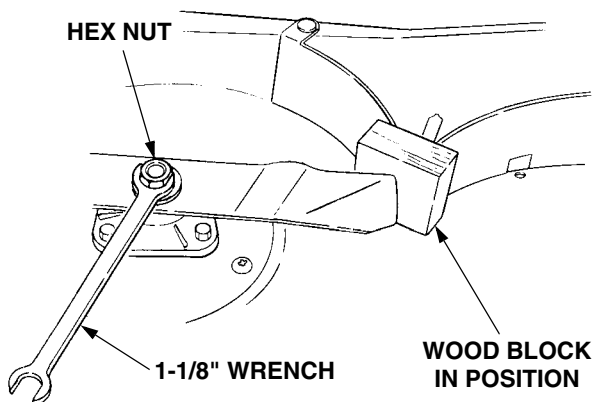
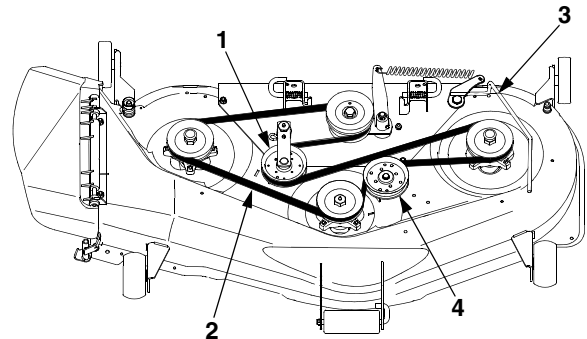

Figure 6-18

SPINDLE DRIVE BELT REPLACEMENT

In order to replace the spindle drive belt, refer to Figure 6-19 and proceed as follows:

1. Disengage the idler arm lever from its stop bracket and rotate the lever to the outside of the deck to release the spring tension.
2. Remove the hardware that secures the spindle belt covers to the deck.
3. Remove the spindle belt covers to expose the belt.



- | | |
|-------------------------|-----------------------|
| 1. Movable Idler Pulley | 3. Idler Arm Lever |
| 2. Spindle Drive Belt | 4. Fixed Idler Pulley |

Figure 6-19

4. Pull the movable flat idler pulley away from the backside of the belt and remove the old drive belt.
5. Install a new belt on the spindle pulleys and position the flat idler pulley against the backside of the belt so that the belt is tensioned. Refer to Figure 6-19 for the proper routing of the belt.
6. Reinstall the spindle belt covers.
7. Engage the idler arm lever into its stop bracket.

Section 7: Trouble Shooting

Possible Cause

Possible Remedy

HARD TO START

No gasoline in fuel tank or carburetor	Fill the tank with gasoline. Check the fuel line, carburetor and fuel filter.
Fuel line or carburetor clogged	Clean the fuel line and carburetor with a commercial carburetor cleaner.
Fuel filter plugged	Replace.
Water in gasoline	Drain the fuel tank and carburetor. Use new fuel and dry the spark plugs.
Choked improperly. Flooded engine	Follow the starting instructions.
Defective ignition or loose wiring	Check the wiring, spark plugs or fuse.
Defective battery	Check and service. Refer to “ BATTERY. ”
Spark plug dirty or improper gap	Clean, adjust the gap to .030-inch or replace the plug.

ENGINE OPERATES IRREGULARLY OR KNOCKS

Engine incorrectly timed.....	*
Spark plug dirty; wrong gap or wrong type	Clean, reset the gap or replace.
Poor or weak spark	Check the spark plugs and wiring.
Carburetor setting incorrect	*
Poor grade fuel or water in fuel	Drain and use a good grade of clean fuel.
Engine overheating	Refer to “ MAINTENANCE. ”
Engine valves at fault.....	*
Engine smokes	*
Oil level rises due to gasoline in crankcase	*
Air filter becomes oil and fuel soaked	*
Engine leaks oil	*
Misfiring.....	*
Other engine problems	*
Excessive oil in air cleaner.....	Be sure that oil dipstick is fully seated and all excess oil is squeezed out of the pre-cleaner foam element.

PTO CLUTCH WILL NOT ENGAGE

Low or zero voltage.....	Check battery. Charge or replace. Check charging system. Check for worn or broken wiring or connections. Check clutch coil resistance. Check switch.
Rotor/armature air gap too large	Rotor/armature worn. Replace PTO clutch.

* See your authorized dealer.

Trouble Shooting

Possible Cause	Possible Remedy
LACK OF POWER	
Air cleaner clogged	Service the air cleaner element. Refer to “ MAINTENANCE. ”
Engine overload	Reduce the load.
Engine overheated	Make sure the air intake screen, shrouding, and engine cooling fins are free of accumulated dirt and debris. Refer to “ MAINTENANCE. ”
Fuel tank air vent clogged	Remove obstruction from the vent in the fuel tank cap.
Air leakage between carburetor and engine	Remove air cleaner. Tighten the carburetor and manifold mounting nuts. Replace any damaged parts as indicated in “ MAINTENANCE. ”
Incorrect timing or faulty ignition	*
Brake dragging	Adjust the brake. Refer to “ ADJUSTMENTS. ”
Insufficient cooling air — dirt or debris clogging the: air intake screen • shrouds • cooling fins	Keep the air intake screen and cooling fins clean; refer to “ MAINTENANCE. ”
Oil level incorrect	Engine oil level must not be over the “FULL” mark or below the “LOW” mark on dipstick. Refer to “ MAINTENANCE. ”

* See your authorized dealer.

Section 9: Optional Equipment And Accessories

When you purchased your tractor, you probably had it completely equipped for your particular needs at the time. However, later you may wish to obtain optional equipment or accessories. Refer to the chart below for a list of optional equipment and accessories currently available through your *Cub Cadet* dealer.

Description	Model Number
50" Mulch Kit	190-193-100
Triple Bagger	190-283-100
32 Cu. Ft. Mow -N- Vac	190-217B-100
Hydraulic Tiller	190-002-100
Electric Sleeve Hitch	190-827-100
42" Front Blade	190-302-100
Front/Rear Weight Bracket	190-307-100
42" Snow Thrower	190-341-100
Suitcase Weights	190-390-100
10 Cu. Ft. Poly Cart	19A-106-100
18 Cu. Ft. Steel Cart	19A-102-100
54" Mulch Kit	590-507-100
Broadcast Spreader	19A-105-100
Lawn Dethatcher, 48"	19A-107-100
Spike Aerator, 48"	19A-109-100
Plug Aerator, 48"	19A-108-100
Lawn Sweeper, 42"	19A-103-100
Sprayer, 25 gallon	19A-104-100
Lawn Roller, 48"	19A-113-100

Section 10: Specifications

	GT 2550
CAPACITIES	
Fuel Tank	2.0 gallons
Crankcase (approximately)	4 pints
Transmission Case (approximately)	6 qts.
HYDROSTATIC DRIVE	
Speed: Forward	0 to 6 mph
Reverse	0 to 3 mph
ENGINE	
Make and Model	Kohler Command
Horsepower	22 HP
Cylinders	2
Bore	3.03 in.
Stroke	2.64 in.
Displacement (cubic inches)	38.1
Engine Speed (governed)	
Low Speed	1200 RPM
High Speed (no load)	3600 RPM ± 75
Ignition	Battery
Spark Plug Gap (Cub Cadet No. 759-3336)030 in.
ELECTRICAL SYSTEM	
System Voltage	12 volt neg. ground
Battery	725-1707D
Alternator	15 amp regulated
Fuse (auto type)	25 amp
Head Lamp Bulb	725-0963
BRAKES	Internal expanding
TIRE SIZES	
Front	16 x 6.5-8
Rear	23 x 9.5-12
DIMENSIONS	
Tread:	
Front with 16 x 6.5-8 tires	31.5 in.
Rear with 23 x 9.5-12 tires	30.25 in.
Wheelbase	47.00 in.
Length, over all	72.00 in.
Width, over all (w/ mower deck - chute up)	57.00 in.
Height, over all (to top of steering wheel)	42.00 in.
Ground Clearance	6.00 in.
Turning Radius	28.0 in.

Specifications are subject to change without notice.

NOTES

**CALIFORNIA EMISSION CONTROL WARRANTY STATEMENT
YOUR WARRANTY RIGHTS AND OBLIGATIONS**

The California Air Resources Board and MTD Consumer Group Inc are pleased to explain the evaporative emission control system warranty on your 2008 lawn mower. In California, new lawn mowers must be designed, built and equipped to meet the State's stringent anti-smog standards. MTD Consumer Group Inc must warrant the EECS on your lawn mower for the period of time listed below provided there has been no abuse, neglect or improper maintenance of your lawn mower.

Your EECS may include parts such as the carburetor, fuel-injection system, the ignition system, catalytic converter, fuel tanks, fuel lines, fuel caps, valves, canisters, filters, vapor hoses, clamps, connectors, and other associated emission-related components.

Where a warrantable condition exists, MTD Consumer Group Inc will repair your lawn mower at no cost to you including diagnosis, parts and labor.

MANUFACTURER'S WARRANTY COVERAGE:

This evaporative emission control system is warranted for two years. If any evaporative emission-related part on your equipment is defective, the part will be repaired or replaced by MTD Consumer Group Inc.

OWNER'S WARRANTY RESPONSIBILITIES:

As the lawn mower owner, you are responsible for performance of the required maintenance listed in your owner's manual. MTD Consumer Group Inc recommends that you retain all receipts covering maintenance on your lawn mower, but MTD Consumer Group Inc cannot deny warranty solely for the lack of receipts.

As the lawn mower owner, you should however be aware that MTD Consumer Group Inc may deny you warranty coverage if your lawn mower or a part has failed due to abuse, neglect, or improper maintenance or unapproved modifications.

You are responsible for presenting your lawn mower to MTD Consumer Group Inc's distribution center or service center as soon as the problem exists. The warranty repairs should be completed in a reasonable amount of time, not to exceed 30 days. If you have a question regarding your warranty coverage, you should contact the MTD Consumer Group Inc Service Department at 1-800-800-7310.

GENERAL EMISSIONS WARRANTY COVERAGE:

MTD Consumer Group Inc warrants to the ultimate purchaser and each subsequent purchaser that the lawn mower is: Designed, built and equipped so as to conform with all applicable regulations; and free from defects in materials and workmanship that cause the failure of a warranted part to be identical in all material respects to that part as described in MTD Consumer Group Inc's application for certification.

The warranty period begins on the date the lawn mower is delivered to an ultimate purchaser or first placed into service. The warranty period is two years.

Subject to certain conditions and exclusions as stated below, the warranty on emission-related parts is as follows:

1. Any warranted part that is not scheduled for replacement as required maintenance in the written instructions supplied, is warranted for the warranty period stated above. If the part fails during the period of warranty coverage, the part will be repaired or replaced by MTD Consumer Group Inc according to subsection (4) below. Any such part repaired or replaced under warranty will be warranted for the remainder of the period.
2. Any warranted part that is scheduled only for regular inspection in the written instructions supplied is warranted for the warranty period stated above. Any such part repaired or replaced under warranty will be warranted for the remaining warranty period.
3. Any warranted part that is scheduled for replacement as required maintenance in the written instructions supplied is warranted for the period of time before the first scheduled replacement date for that part. If the part fails before the first scheduled replacement, the part will be repaired or replaced by MTD Consumer Group Inc according to subsection (4) below. Any such part repaired or replaced under warranty will be warranted for the remainder of the period prior to the first scheduled replacement point for the part.
4. Repair or replacement of any warranted part under the warranty provisions herein must be performed at a warranty station at no charge to the owner.
5. Notwithstanding the provisions herein, warranty services or repairs will be provided at all of our distribution centers that are franchised to service the subject engines or equipment.
6. The lawn mower owner will not be charged for diagnostic labor that is directly associated with diagnosis of a defective, emission-related warranted part, provided that such diagnostic work is performed at a warranty station.
7. MTD Consumer Group Inc is liable for damages to other engine or equipment components proximately caused by a failure under warranty of any warranted part.
8. Throughout the lawn mower warranty period stated above, MTD Consumer Group Inc will maintain a supply of warranted parts sufficient to meet the expected demand for such parts.
9. Any replacement part may be used in the performance of any warranty maintenance or repairs and must be provided without charge to the owner. Such use will not reduce the warranty obligations of MTD Consumer Group Inc.
10. Add-on or modified parts that are not exempted by the Air Resources Board may not be used. The use of any non-exempted add-on or modified parts by the ultimate purchaser will be grounds for disallowing a warranty claims. MTD Consumer Group Inc will not be liable to warrant failures of warranted parts caused by the use of a non-exempted add-on or modified part.

WARRANTED PARTS:

The repair or replacement of any warranted part otherwise eligible for warranty coverage may be excluded from such warranty coverage if MTD Consumer Group Inc demonstrates that the lawn mower has been abused, neglected, or improperly maintained, and that such abuse, neglect, or improper maintenance was the direct cause of the need for repair or replacement of the part. That notwithstanding, any adjustment of a component that has a factory installed, and properly operating, adjustment limiting device is still eligible for warranty coverage. The following emission warranty parts list are covered: Fuel Line, Fuel Line Clamps

CUB CADET LLC
MANUFACTURER'S LIMITED WARRANTY FOR
SERIES 2500 TRACTORS

IMPORTANT: To obtain warranty coverage owner must present an original proof of purchase and applicable maintenance records to the servicing dealer. Please see the operator's manual for information on required maintenance and service intervals.

The limited warranty set forth below is given by Cub Cadet LLC with respect to new merchandise purchased or leased and used in the United States and/or its territories and possessions, and by MTD Products Limited with respect to new merchandise purchased or leased and used in Canada and/or its territories and possessions (either entity respectively, "Cub Cadet").

Cub Cadet warrants this product (excluding its *Normal Wear Parts, Batteries, Frame, Front Axle and Drive Shaft and Attachments* as described below) against defects in material and workmanship for a period of three (3) years or one hundred fifty (150) operation hours, whichever comes first, commencing on the date of original retail purchase or lease and will, at its option, repair or replace, free of charge, any part found to be defective in materials or workmanship.

Normal Wear Parts are warranted to be free from defects in material and workmanship for a period of thirty (30) days from the date of original purchase or lease. Normal wear parts include, but are not limited to items such as: belts, blades, blade adapters, grass bags, rider deck wheels, seats, and tires.

Batteries have a one-year prorated limited warranty against defects in material and workmanship, with 100% replacement during the first three months. After three months, the battery replacement credit is based on the months remaining in the twelve (12) month period dating back to the original date of original sale or lease. Any replacement battery will be warranted only for the remainder of the original warranty period.

Frame, Front Axle and Drive Shaft — Cub Cadet warrants the frame, front cast iron pivot axle and drive shaft against defects in material and workmanship for a period of five (5) years or 500 hours, whichever occurs first, commencing on the date of original purchase or lease.

Attachments — Cub Cadet warrants attachments for this product against defects in material and workmanship for a period of two (2) years, commencing on the date of the attachment's original purchase or lease. Attachments include, but are not limited to items such as: grass collectors and mulch kits.

This limited warranty shall only apply if this product has been operated and maintained in accordance with the Operator's Manual furnished with the product, and has not been subject to misuse, abuse, neglect, accident, improper maintenance, alteration, vandalism, theft, fire, water, or damage because of other peril or natural disaster. Damage resulting from the installation or use of any part, accessory or attachment not approved by Cub Cadet for use with the product(s) covered by this manual will void your warranty as to any resulting damage. In addition, Cub Cadet may deny warranty coverage if the hour meter, or any part thereof, is altered, modified, disconnected or otherwise tampered with.

HOW TO OBTAIN SERVICE: Warranty service is available, WITH PROOF OF PURCHASE AND APPLICABLE MAINTENANCE RECORDS, through your local authorized service dealer. To locate the dealer in your area:

In the U.S.A.:

Check your Yellow Pages, or contact Cub Cadet LLC at P.O. Box 361131, Cleveland, Ohio 44136-0019, call 1-877-282- 8684 or log on to our website at www.cubcadet.com.

In Canada:

Contact MTD Products Limited, Kitchener, ON N2G 4J1, call 1-800-668-1238 or log on to our website at www.mtdcanada.com.

Without limiting the foregoing, this limited warranty does not provide coverage in the following cases:

- a. Routine maintenance items such as lubricants, filters, blade sharpening, tune-ups, brake adjustments, clutch adjustments, deck adjustments, and normal deterioration of the exterior finish due to use or exposure.
- b. Service completed by someone other than an authorized service dealer.
- c. Cub Cadet does not extend any warranty for products sold or exported outside of the United States and/or Canada, and their respective possessions and territories, except those sold through Cub Cadet's authorized channels of export distribution.
- d. Replacement parts and/or accessories that are not genuine Cub Cadet parts.
- e. Transportation charges and service calls.

There are no implied warranties, including without limitation any implied warranty of merchantability or fitness for a particular purpose. No warranties shall apply after the applicable period of express written warranty above. No other express warranties beyond those mentioned above, given by any person or entity, including a dealer or retailer, with respect to any product, shall bind Cub Cadet. The exclusive remedy is repair or replacement of the product as set forth above. The terms of this warranty provide the sole and exclusive remedy arising from the sale and/or lease of the products covered hereby. Cub Cadet shall not be liable for any incidental or consequential loss or damage including, without limitation, expenses incurred for substitute or replacement lawn care services or for rental expenses to temporarily replace a warranted product.

Some jurisdictions do not allow the exclusion or limitation of incidental or consequential damages, or limitations on how long an implied warranty lasts, so the above exclusions or limitations may not apply to you.

In no event shall recovery of any kind be greater than the amount of the purchase price of the product sold. **Alteration of safety features of the product shall void this warranty.** You assume the risk and liability for loss, damage, or injury to you and your property and/or to others and their property arising out of the misuse or inability to use the product.

This limited warranty shall not extend to anyone other than the original purchaser or to the person for whom it was purchased as a gift.

HOW LOCAL LAWS RELATE TO THIS WARRANTY: This limited warranty gives you specific legal rights, and you may also have other rights that vary in different jurisdictions.

Cub Cadet LLC, P.O. BOX 361131 CLEVELAND, OHIO 44136-0019, Phone: 1-877-282-8684
MTD Products Limited, Kitchener, ON N2G 4J1, Phone: 1-800-668-1238